

# QANBA

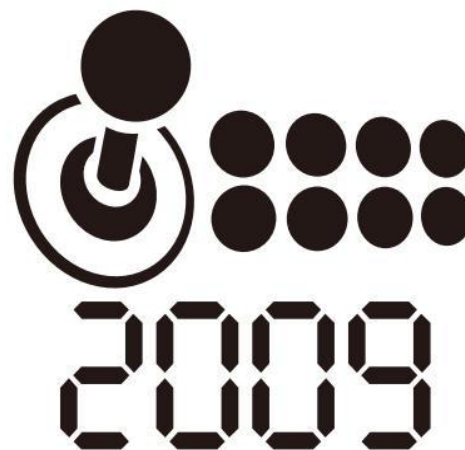

## 2009 ARCADE

### 2009 - 基座安装手册

QANBA 2009  
开放式街机框体 (基座)

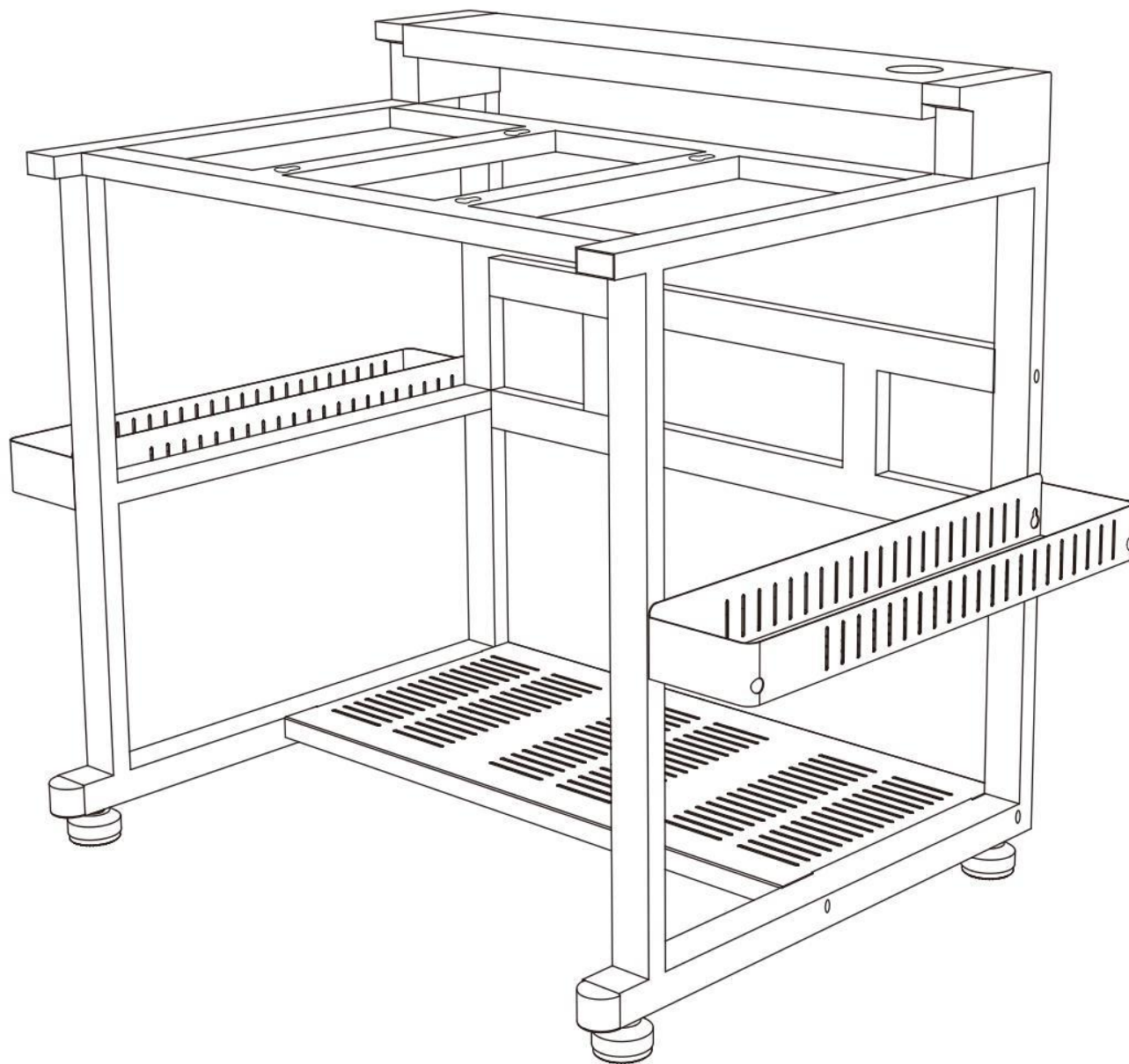

# 基座包物料清单

① 6个金属支架部件

\*拆开两个包装并检查所有物品的数量

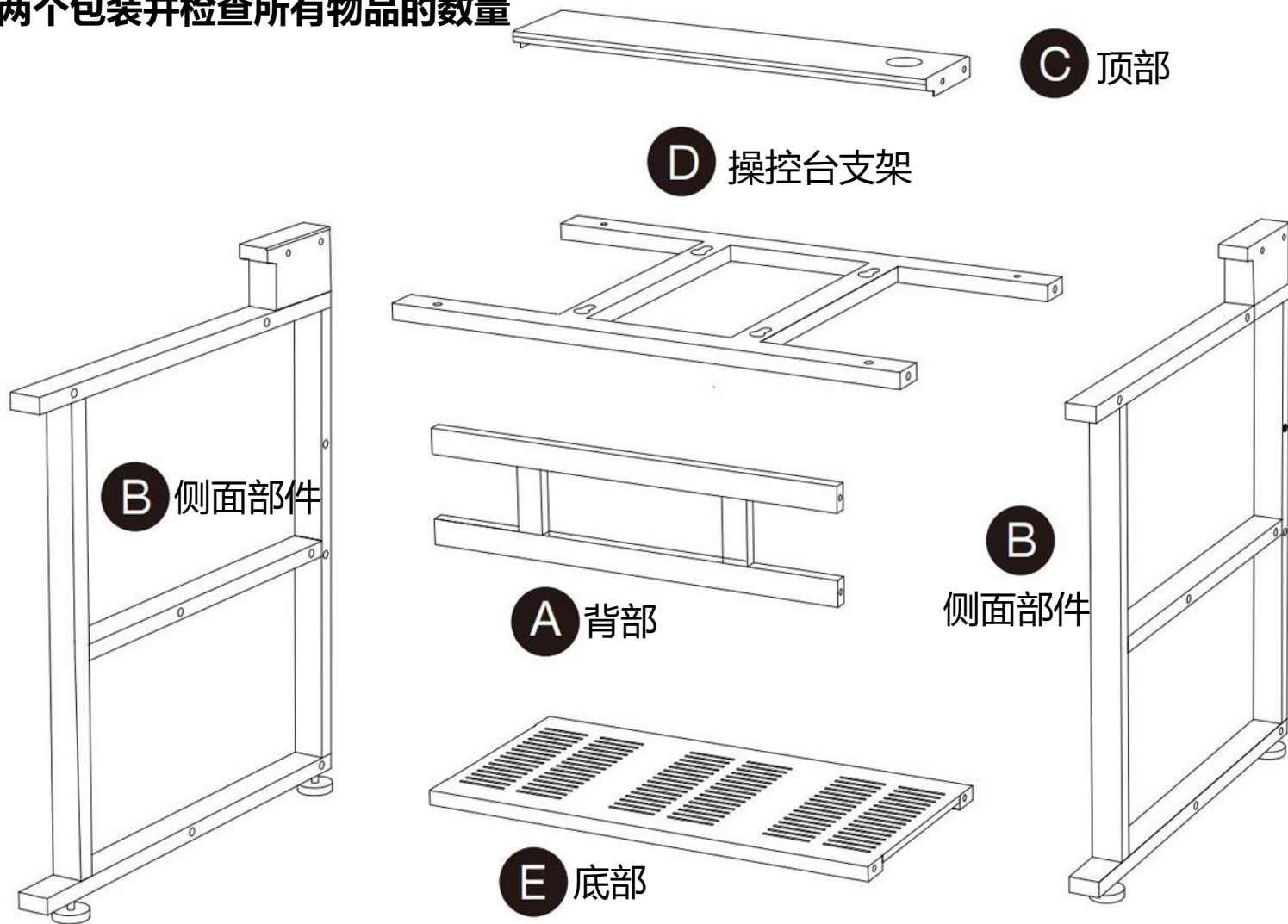

② 配件盒：6x50mm螺丝 x 16，6x30mm螺丝 x 8，十字螺丝刀 x 1，USB线 x 4，6英寸扎带 x 12，10英寸扎带 x 25



**F** 6x50mm  
螺丝 (x 16)



**Q** 6x30mm  
螺丝 (x 8)

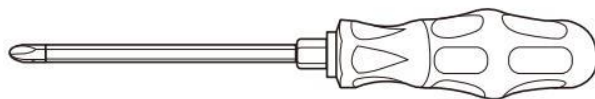

**O** 十字螺丝刀



**L** 6英寸扎带 (x 12)

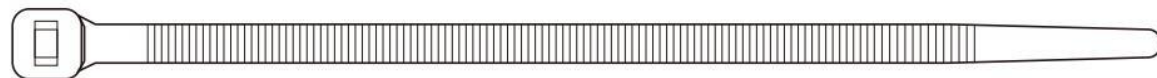

**M** 10英寸扎带 (x 25)

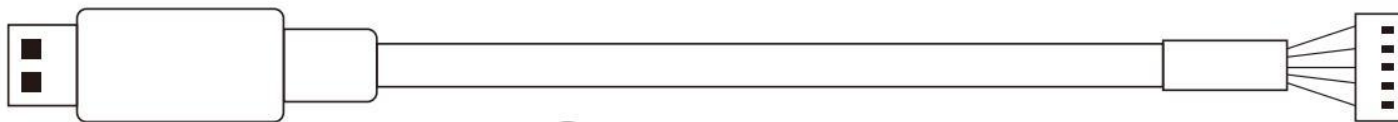

**N** USB线 (x 4)

# 安装前准备目录

安装准备：6个金属支架部件

\*请仔细阅读安装手册。

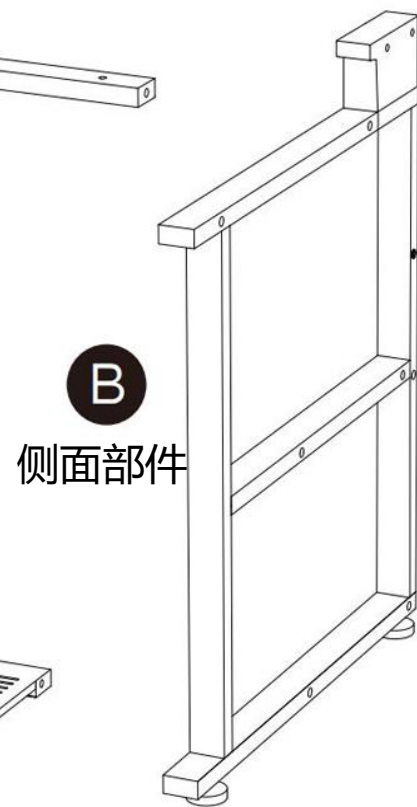
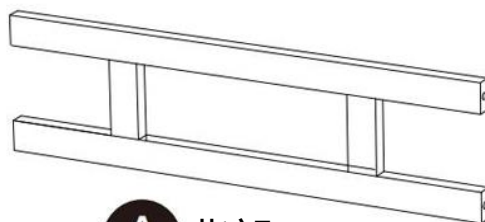
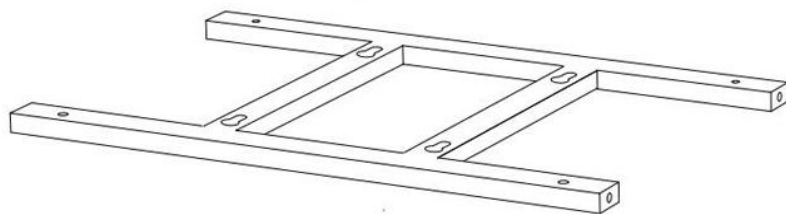
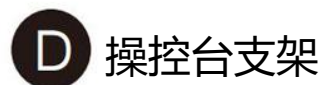
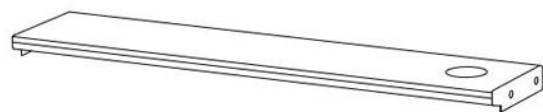
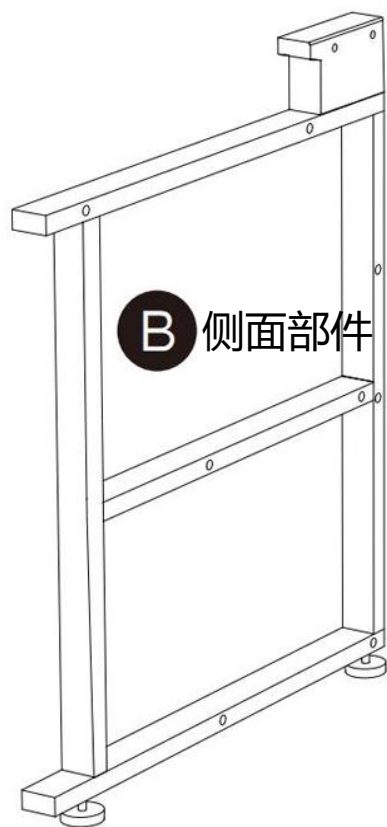

# 安装准备配件

6x50mm螺丝 x 16, 6x30mm螺丝 x 4, 十字螺丝刀 x 1,  
置物篮 x 2, 脚杯 x 4 (2009-1P/2009-2P包装盒内)

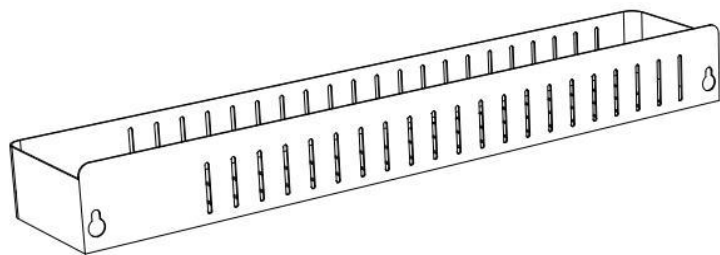

**J** 置物篮

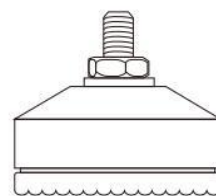

**G** 脚杯 (2)



**F** 6x50mm  
螺丝 (16)



**Q** 6x30mm  
螺丝 (x 8)

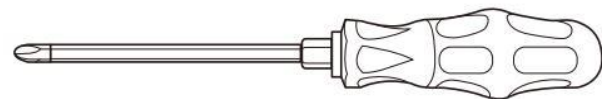

**O** 十字螺丝刀

# 基座安装

步骤1:把4个脚杯(G)拧进2个侧面部件(B)的底部。

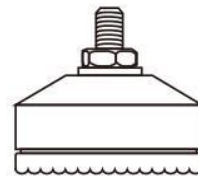

顺时针拧紧

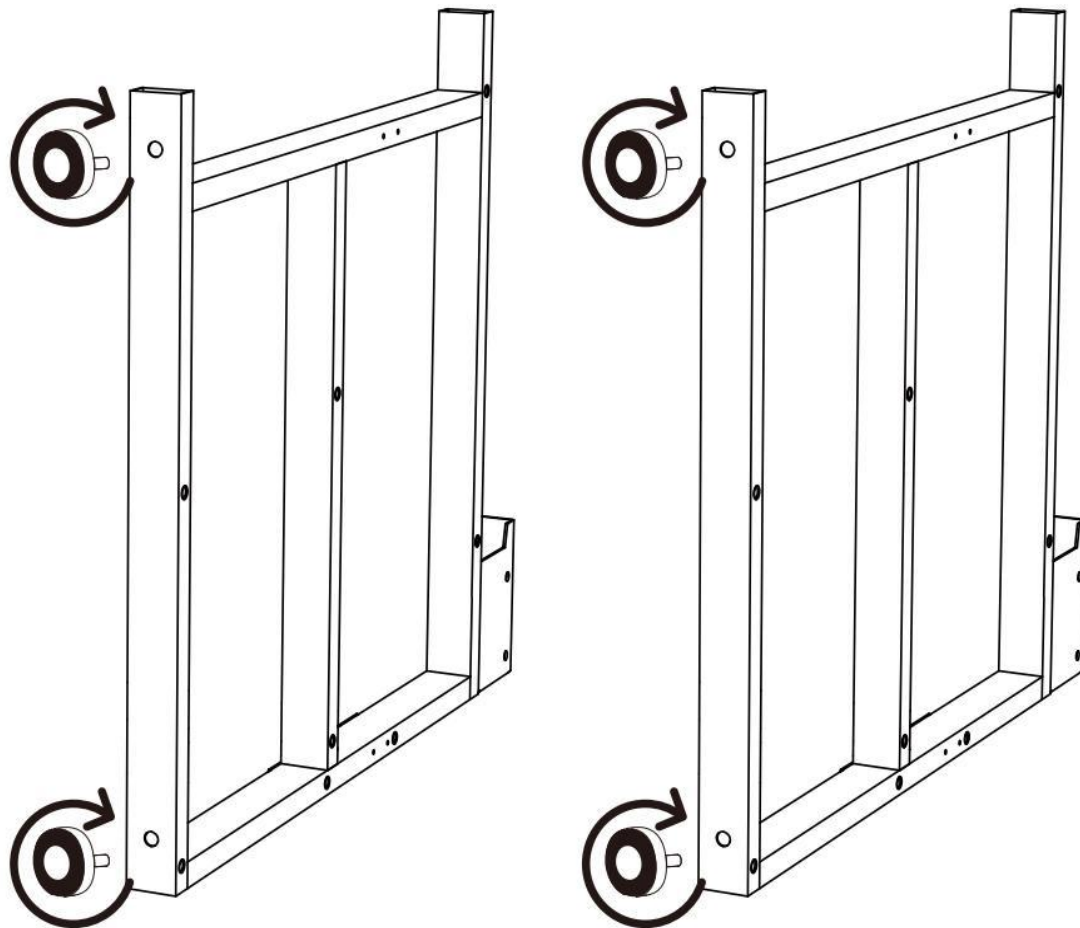

步骤2：将背面部件(A)平放在地板上。

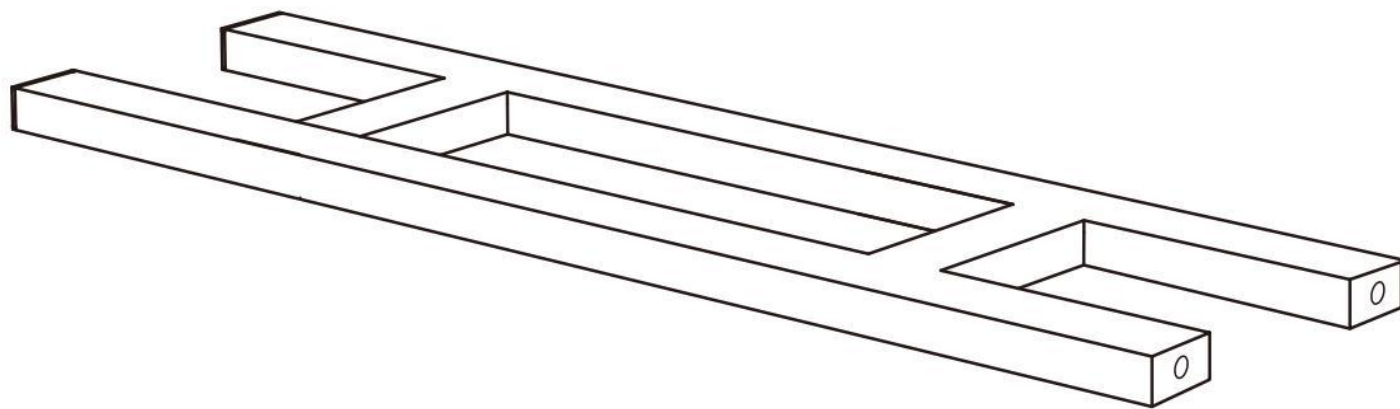

**A** 背面部件



步骤3: 连接背部(A)以及侧面部件(B), 将 6x50mm螺丝(F) 拧紧至80%, 不要完全拧紧。



顺时针拧紧

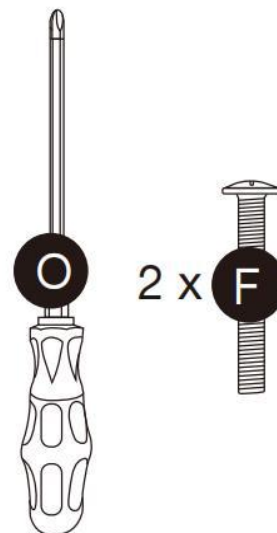
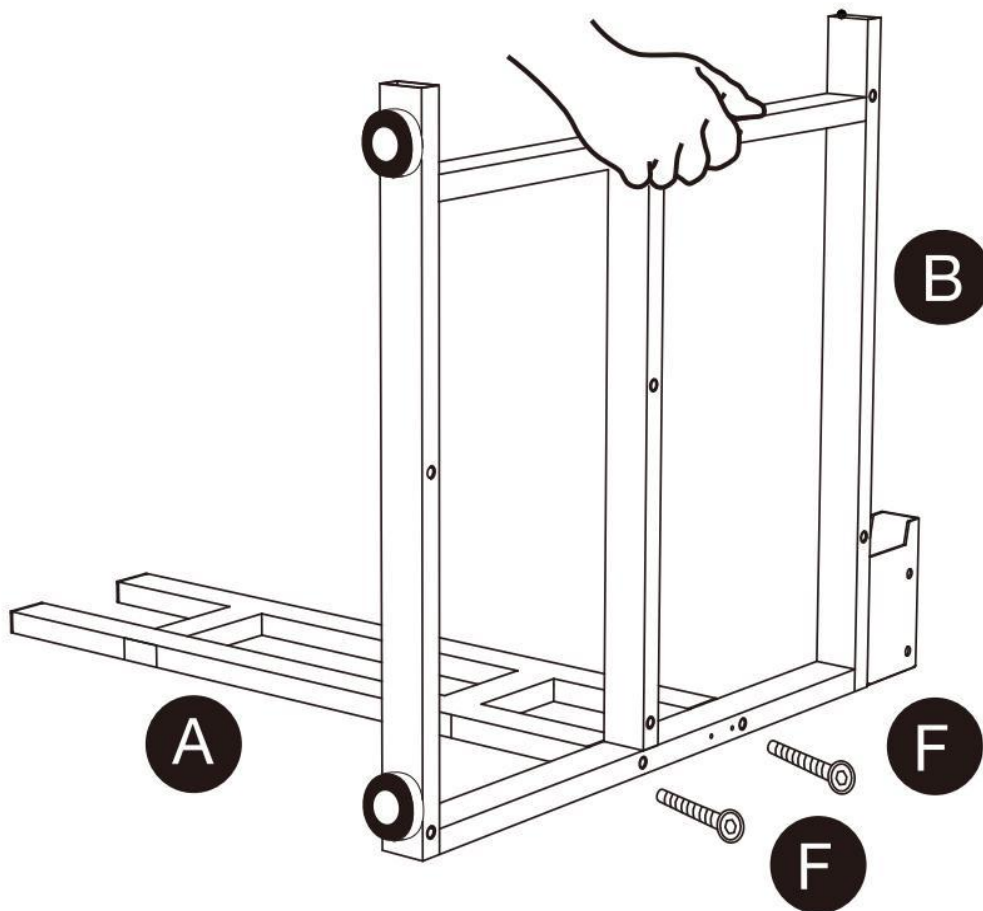

步骤4：重复步骤3安装另外一个侧面部件(B)，

  
顺时针拧紧

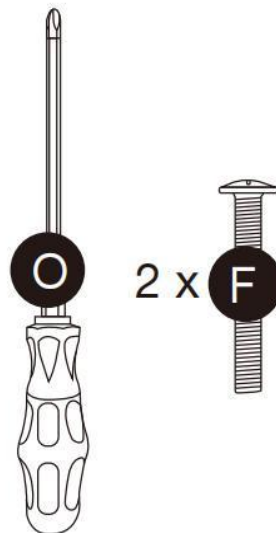
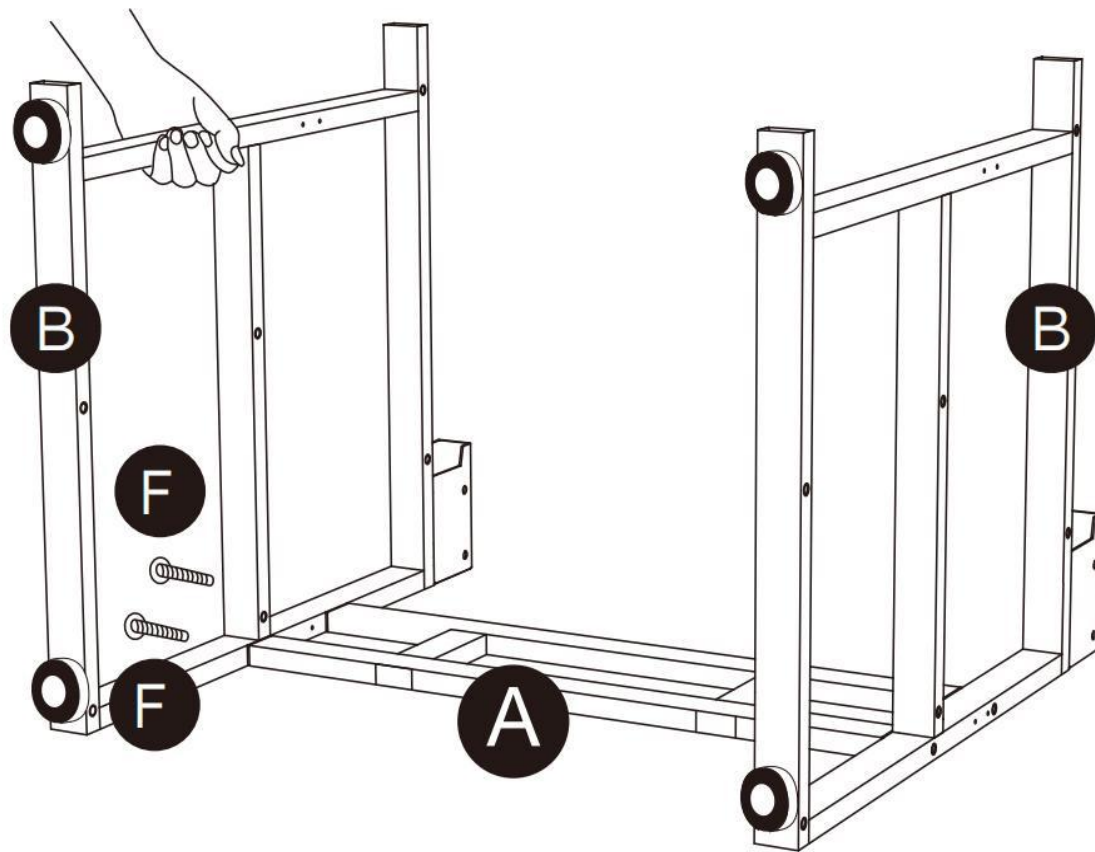

步骤5: 安装顶部(C), 将 6x50mm螺丝 (F)拧紧至 80%, 不要完全拧紧。



顺时针拧紧

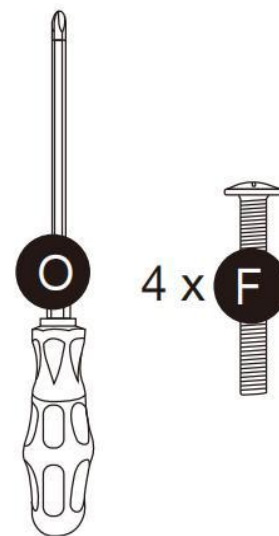
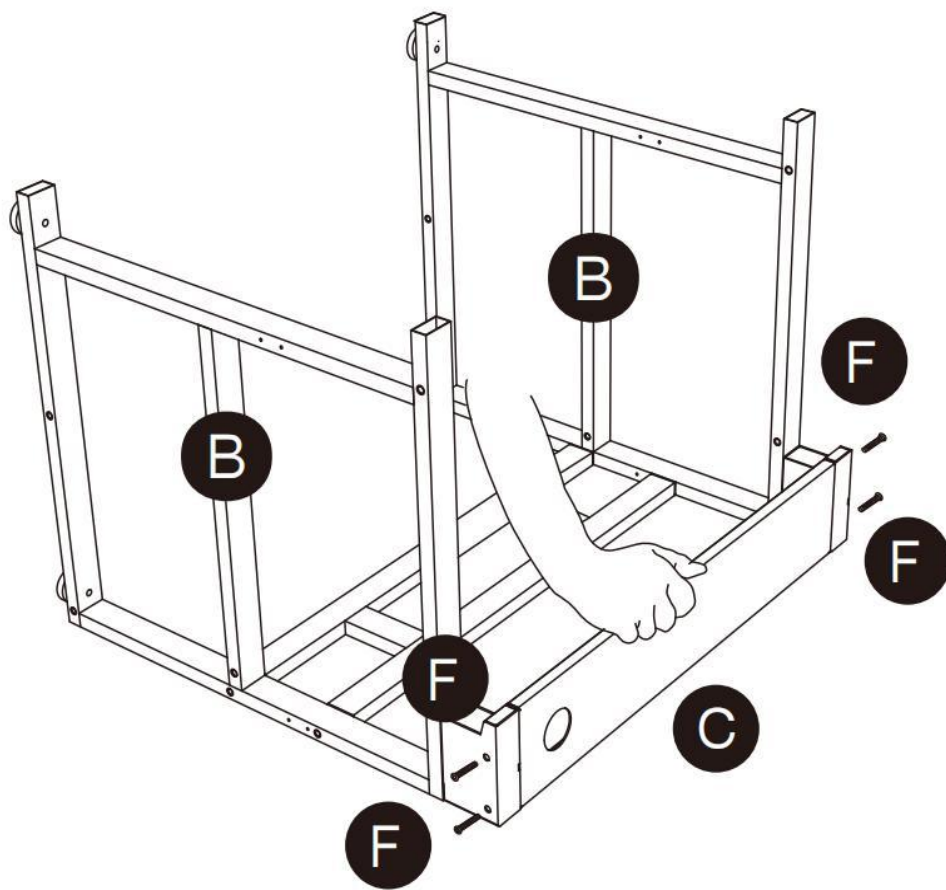

4 x

步骤6: 安装操控台支架(D), 将6x50mm螺丝(F)拧紧至 80%, 不要完全拧紧。



顺时针拧紧

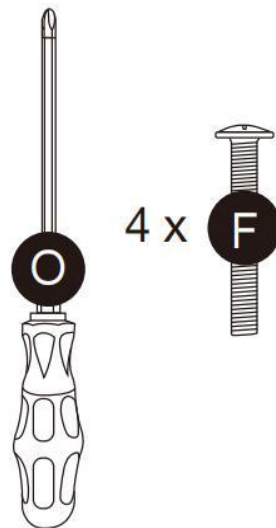
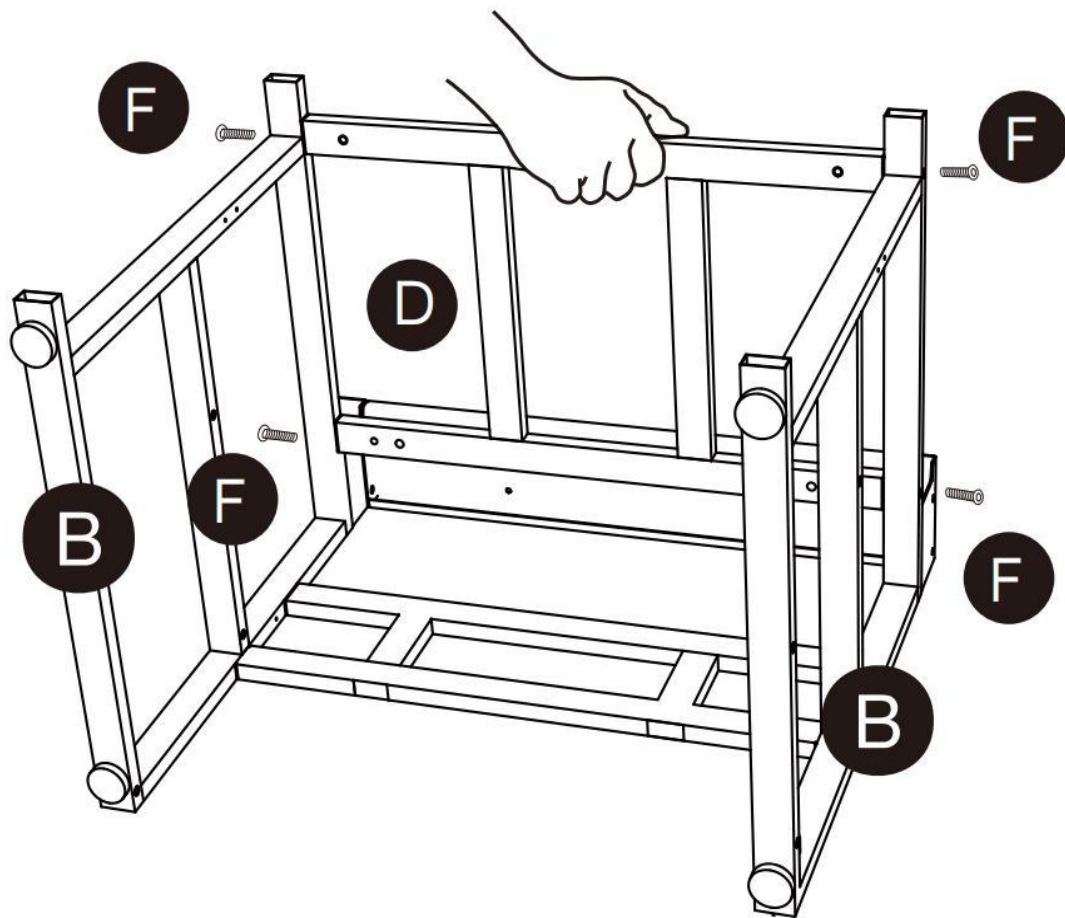

4 x



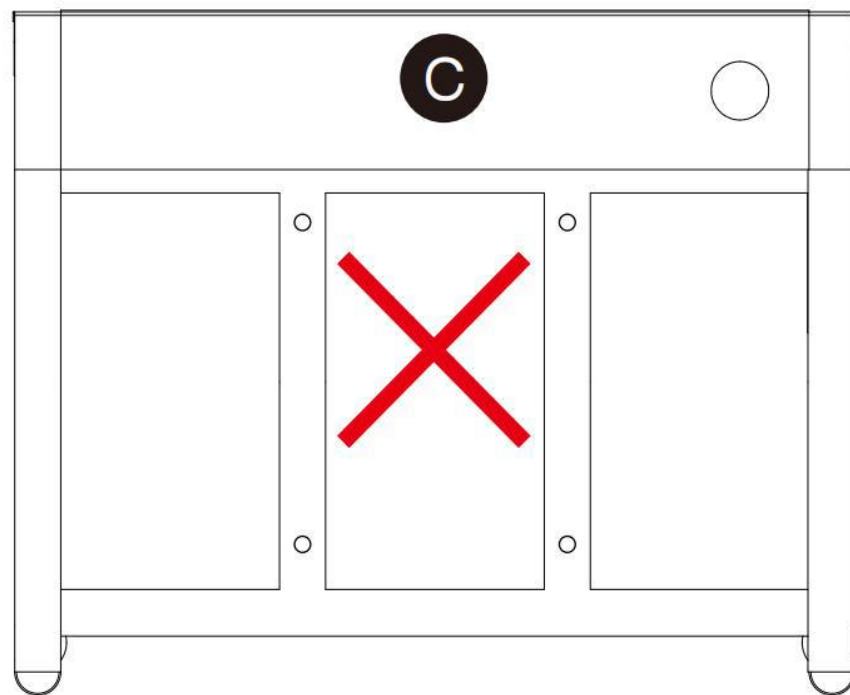
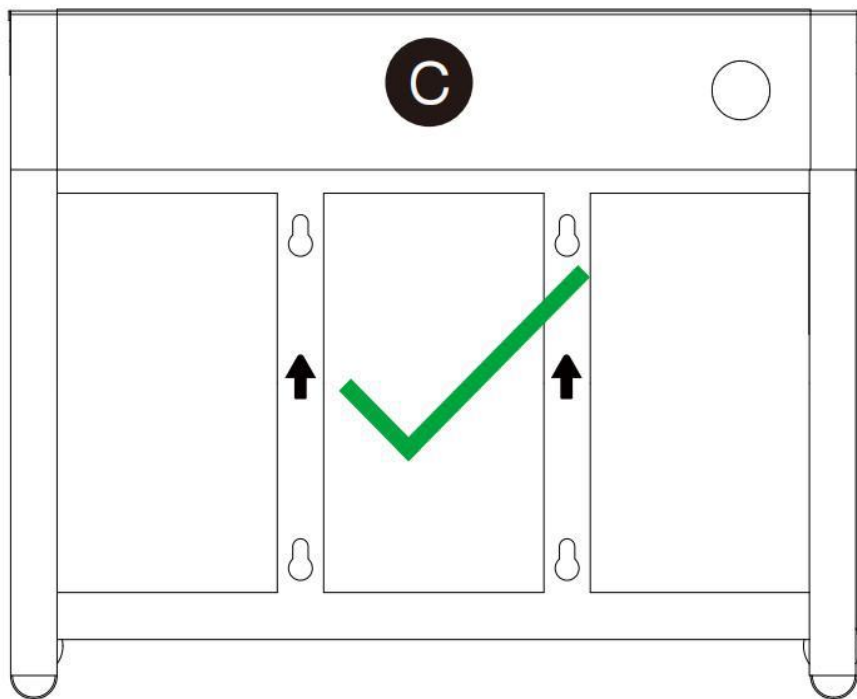

注意：贴纸箭头朝向指示，此面带有防撞贴纸。请按照示意图，插孔朝上，大孔朝外。

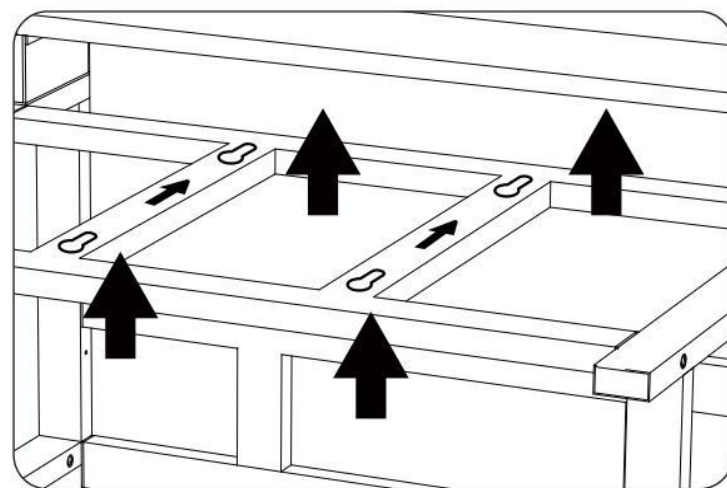

步骤7：安装底部(E)，将6x50mm螺丝(F)拧紧至 80%，不要完全拧紧。

  
顺时针拧紧

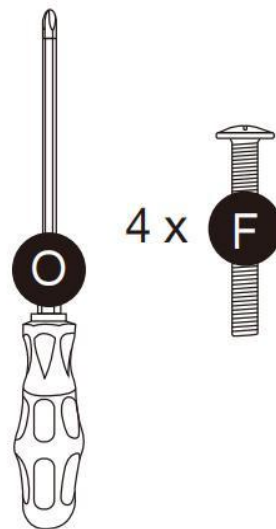
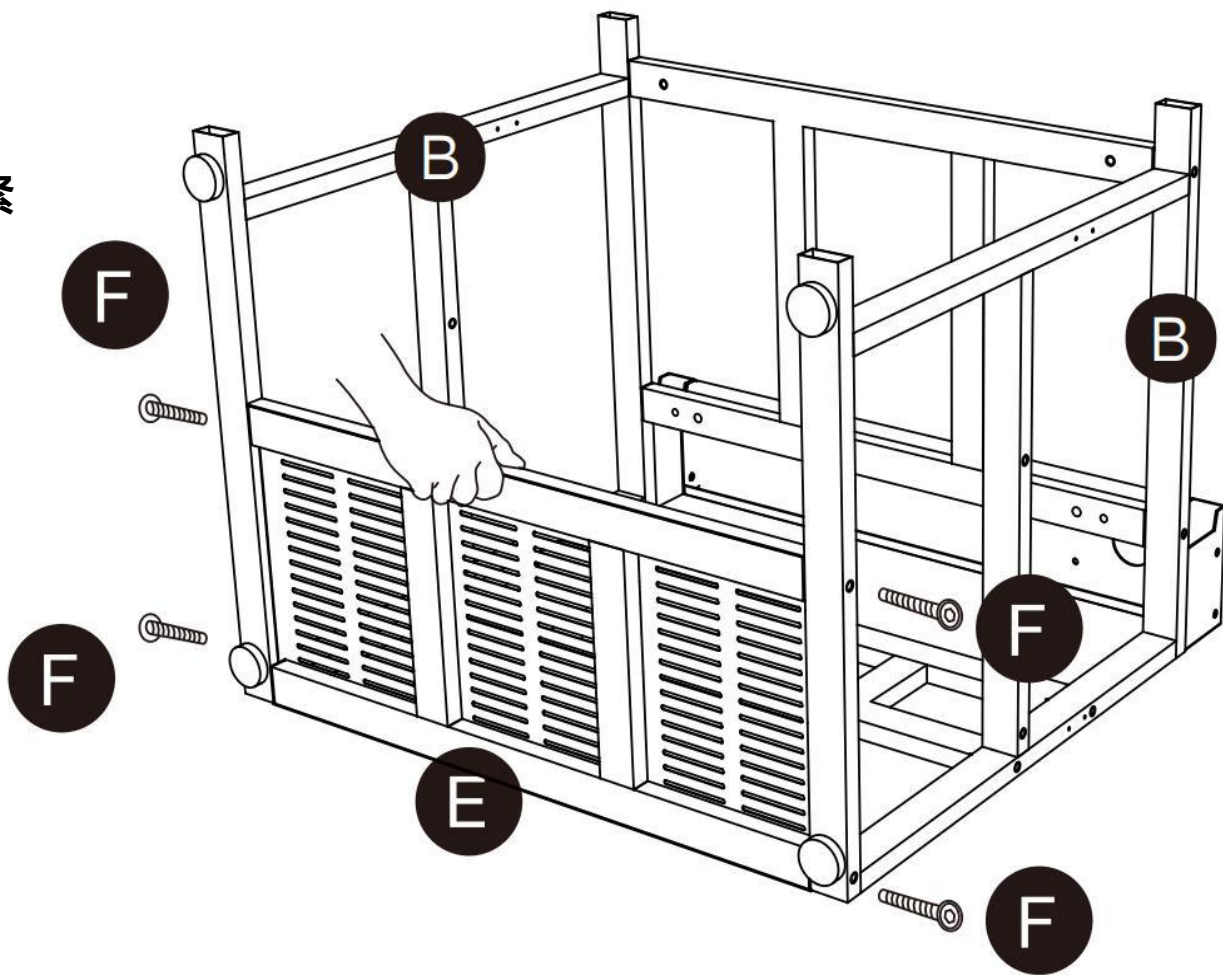

\*底部(E)可以根据需要安装在不同的位置

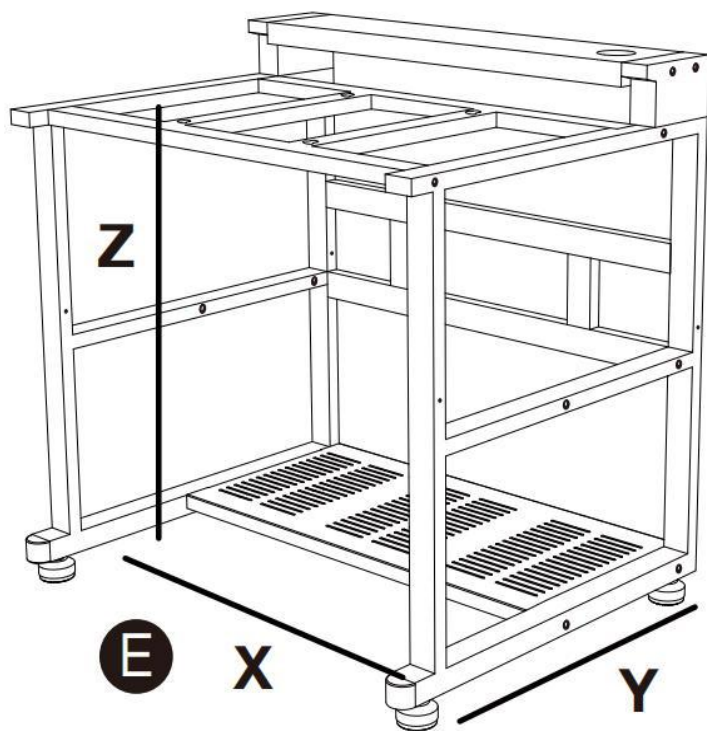

1

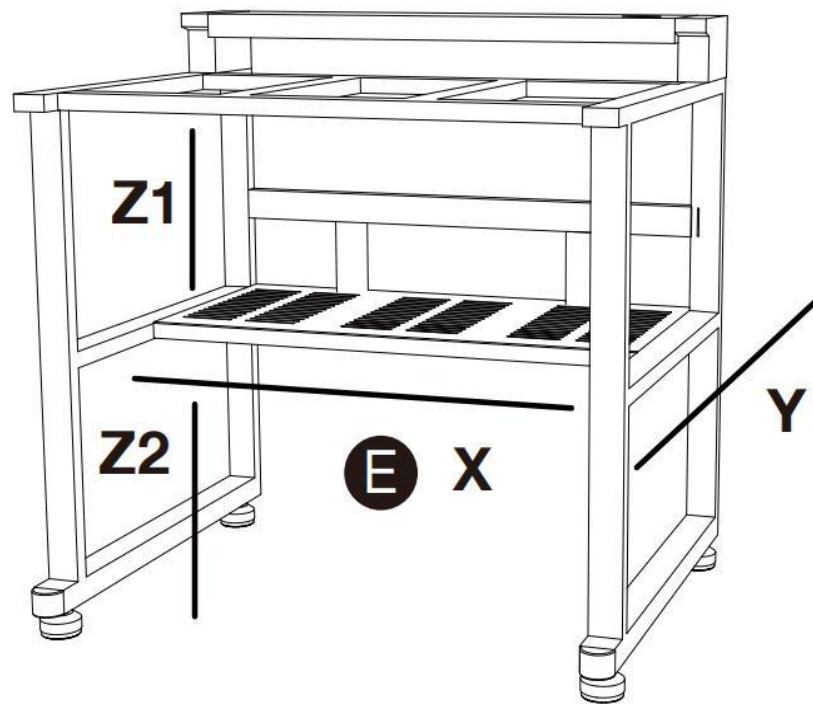

2

步骤8：把基座上 6x50mm螺丝(F)全部拧紧(16颗)。



顺时针拧紧

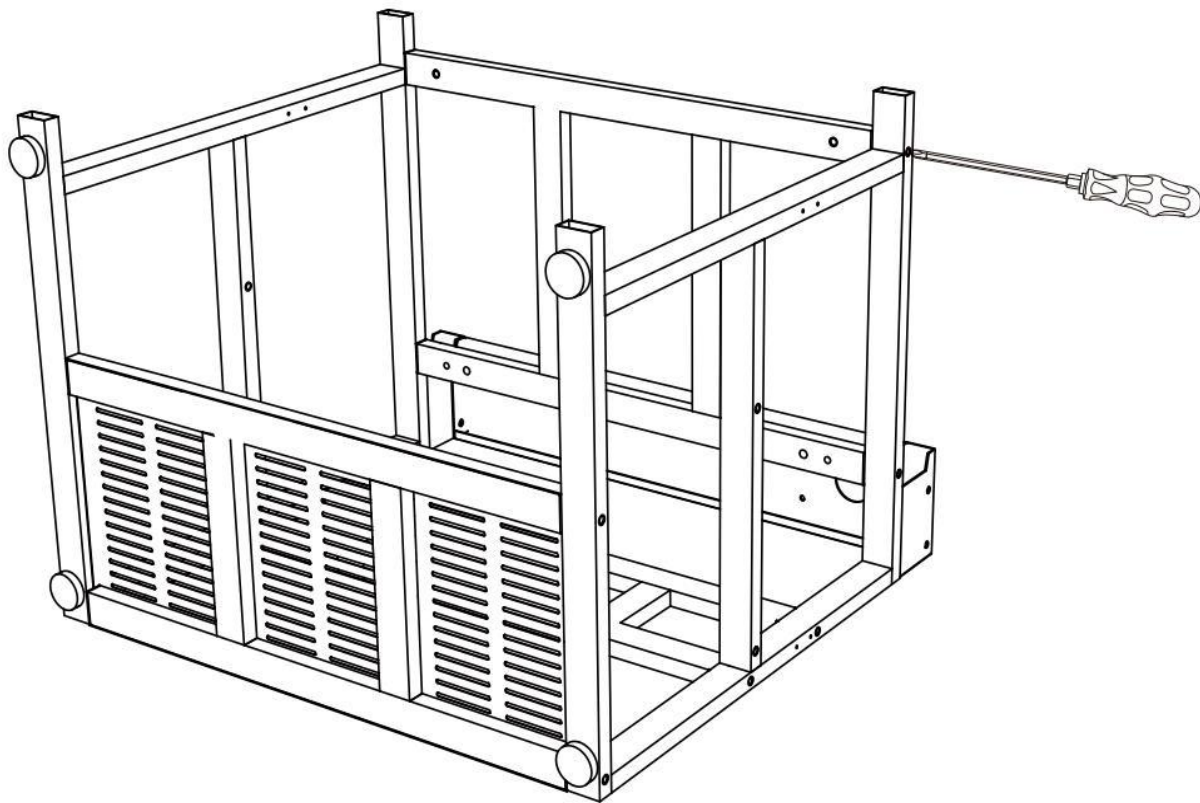



## 步骤9：翻转整个支架

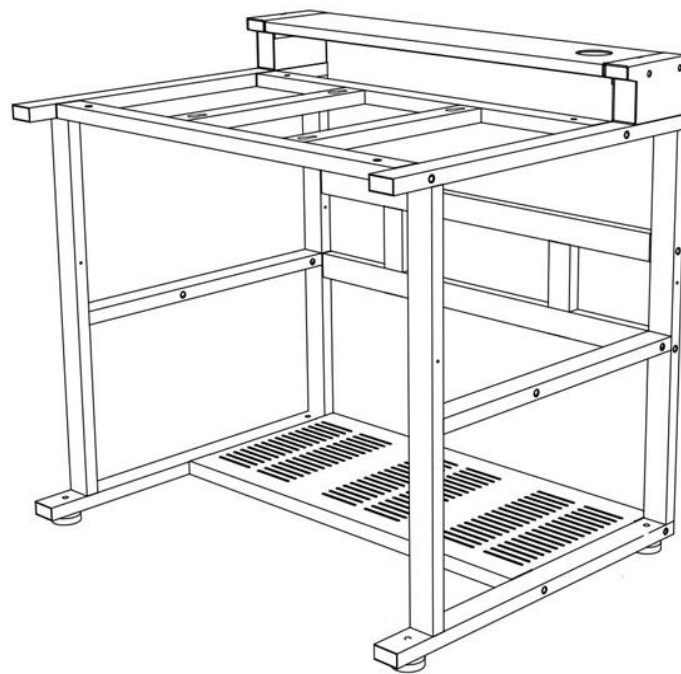
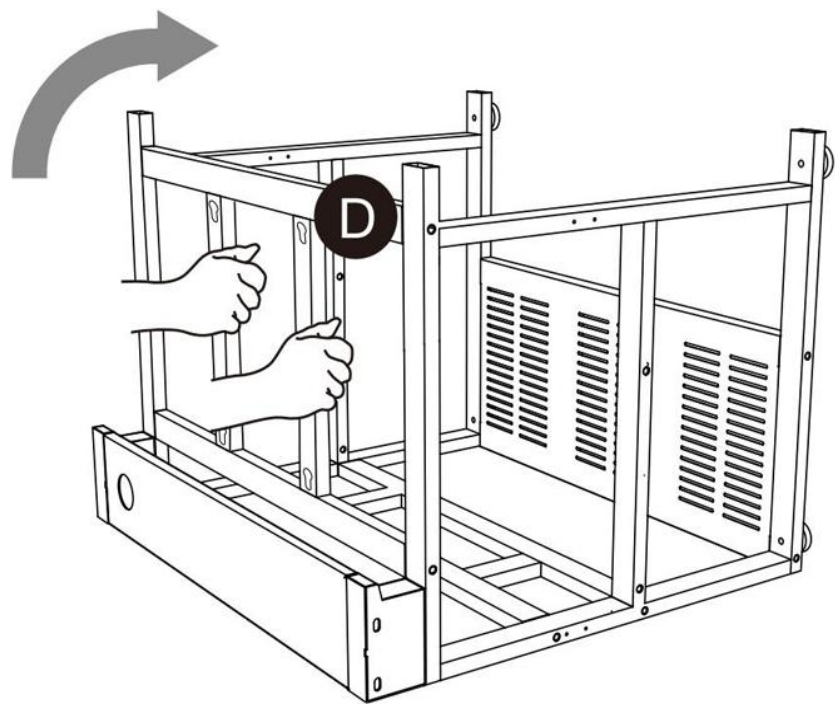

步骤10: 调整脚杯(G)高度, 让基座水平平衡。

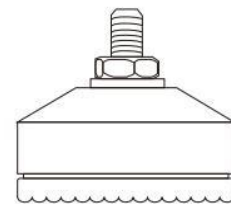

4 x **G**

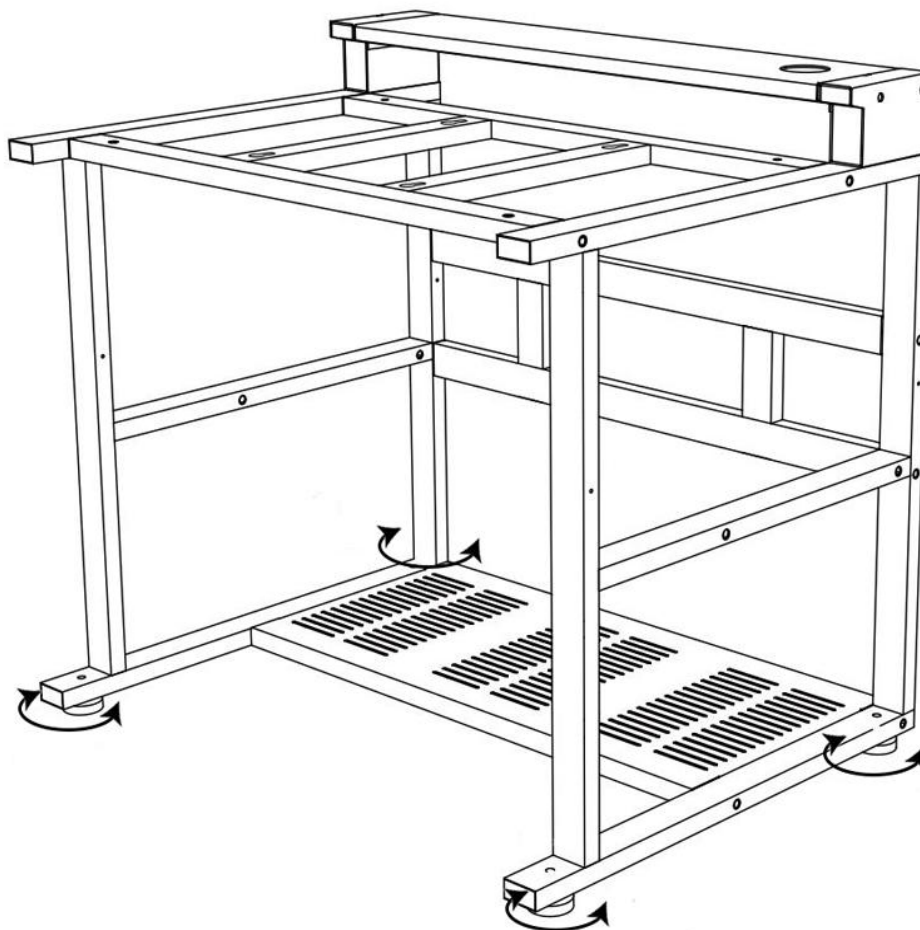

步骤11: 将4个6x30mm螺丝(Q)拧紧至 80%。 不要完全拧紧。



顺时针拧紧

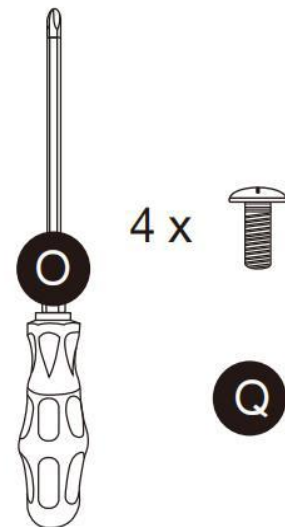
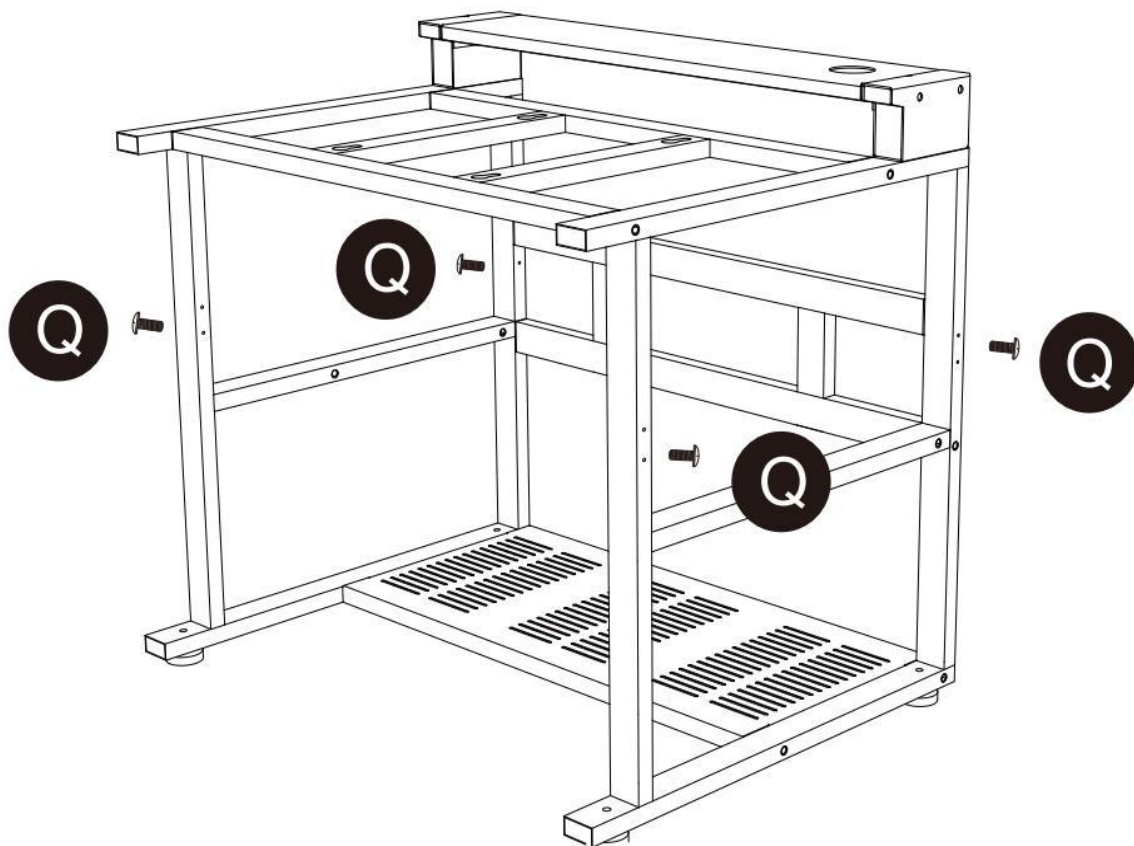

步骤12: 把置物篮(J)挂在4个螺丝拴上, 即可完全拧紧4颗6x30mm螺丝(Q)



顺时针拧紧

