

QANBA

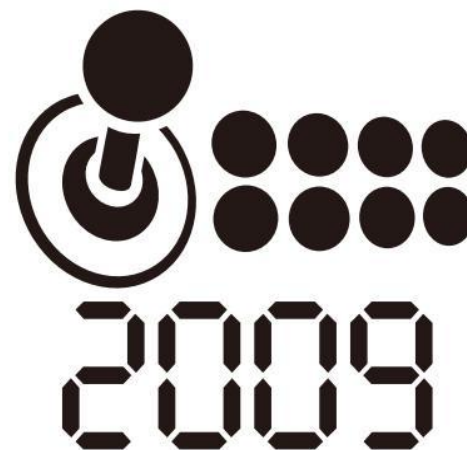

2009 ARCADE

2009 - 基座安裝手冊

QANBA 2009
開放式街機框體 (基座)

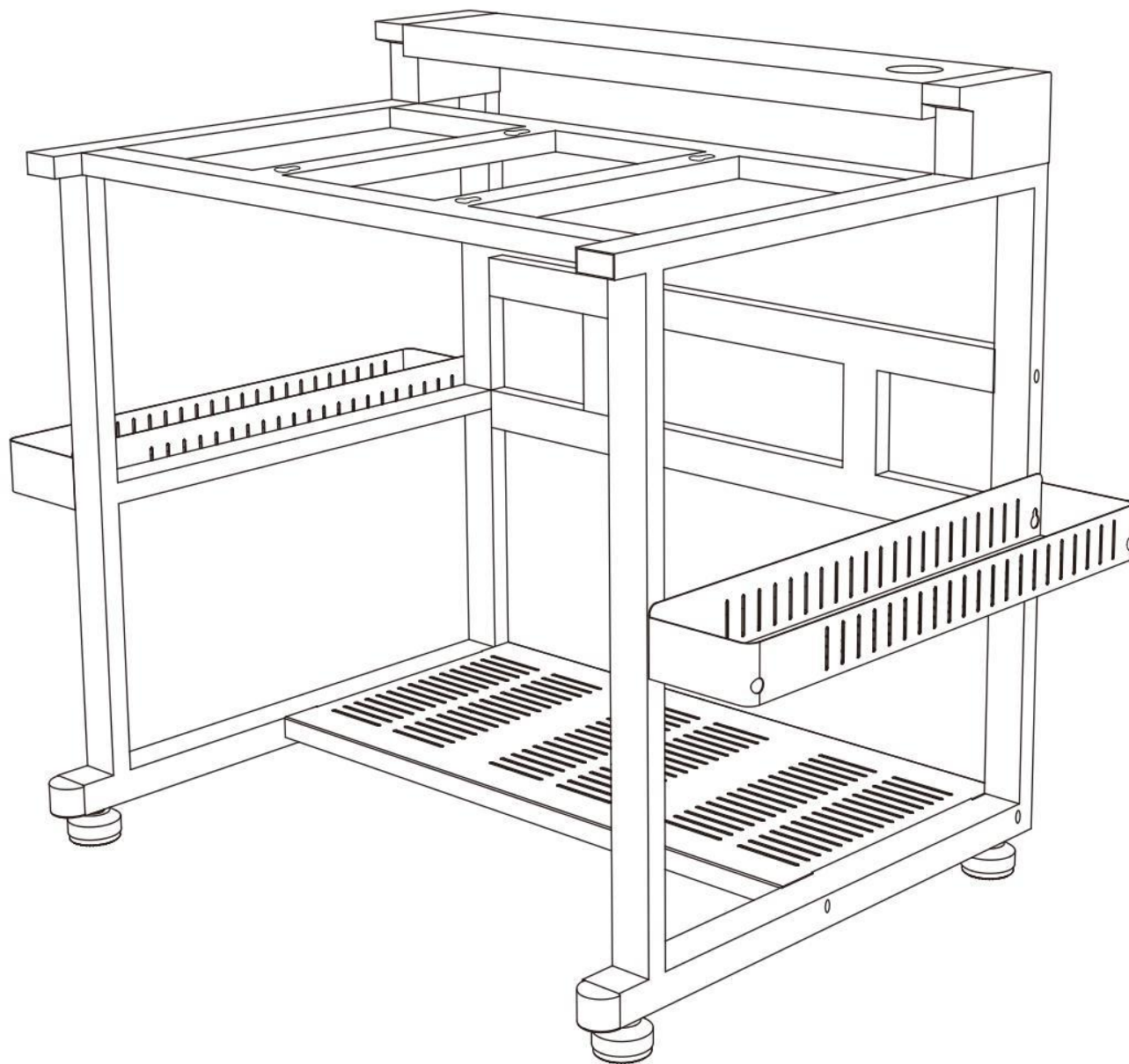

基座包物料清單

① 6個金屬支架

*拆掉兩個包裝並檢查所有物品的數量

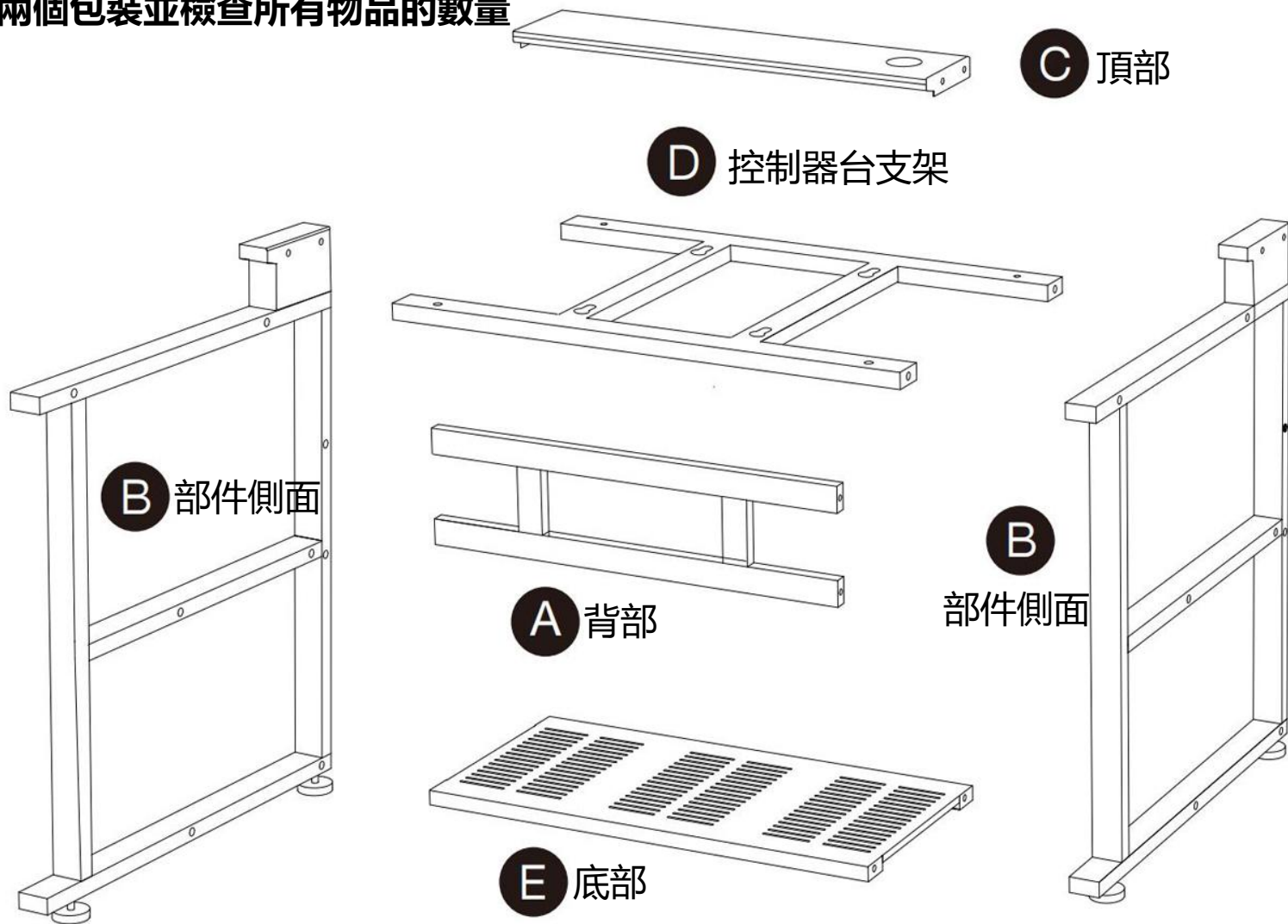

② 配件盒： 6x50mm螺絲x 16 ， 6x30mm螺絲x 8 ， 十字螺絲起子x 1 ， USB線x 4 ， 6吋紮帶x 12 ， 10吋紮帶x 25



F 6x50毫米
螺絲 (x 16)



Q 6x30毫米
螺絲 (x 8)

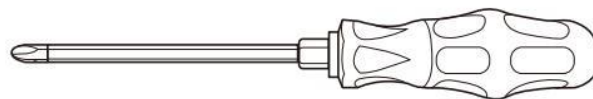

O 十字螺絲批



L 6吋紮帶 (x 12)

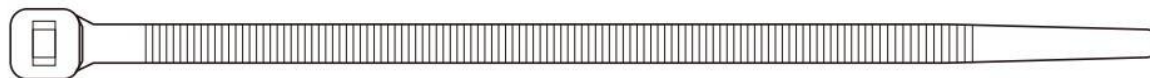

M 10吋紮帶 (x 25)

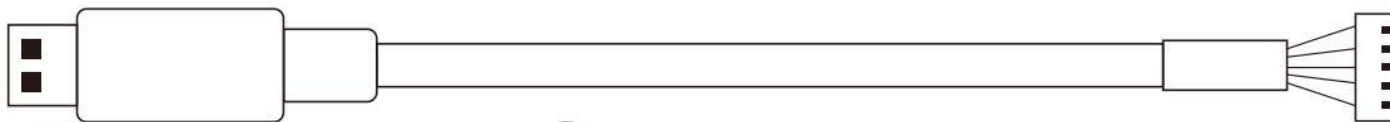

N USB線 (x 4)

安裝前準備目錄

安裝準備：6個金屬支架零件

*請仔細閱讀安裝手冊。

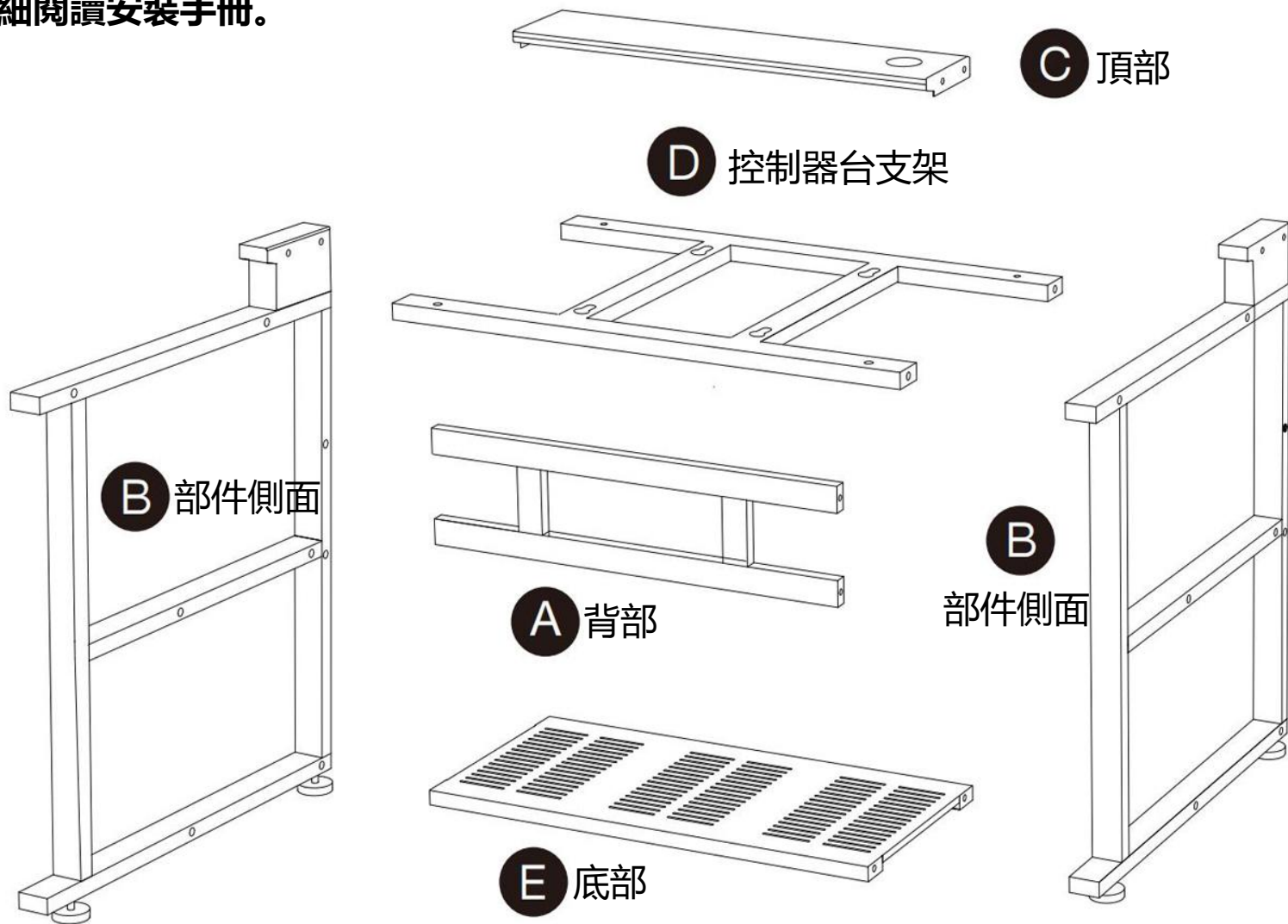

安裝準備配件

6x50mm螺絲x 16， 6x30mm螺絲x4， 十字螺絲起子x 1，
置物籃x 2， 腳杯x4 （ 2009-1P/2009-2P包裝盒內）

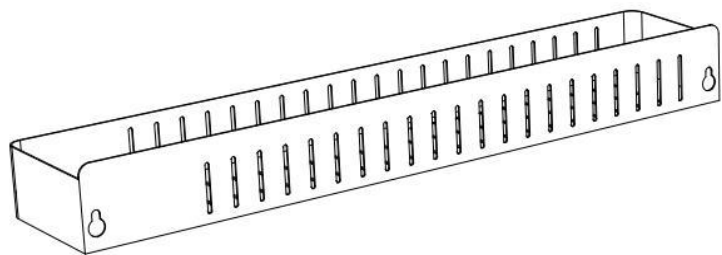

J 置物籃

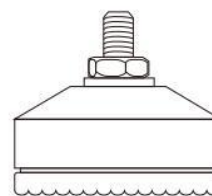

G 腳杯（2）



F 6x50毫米
螺絲（16）



Q 6x30毫米
螺絲（x 8）

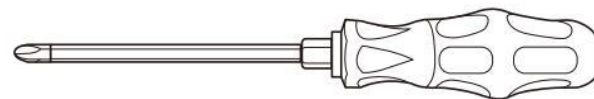

O 十字螺絲批

基礎安裝

步驟1：把4個腳杯(G)旋進2個側邊部件(B)的底部。

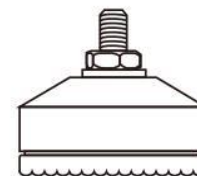

順時針擰緊

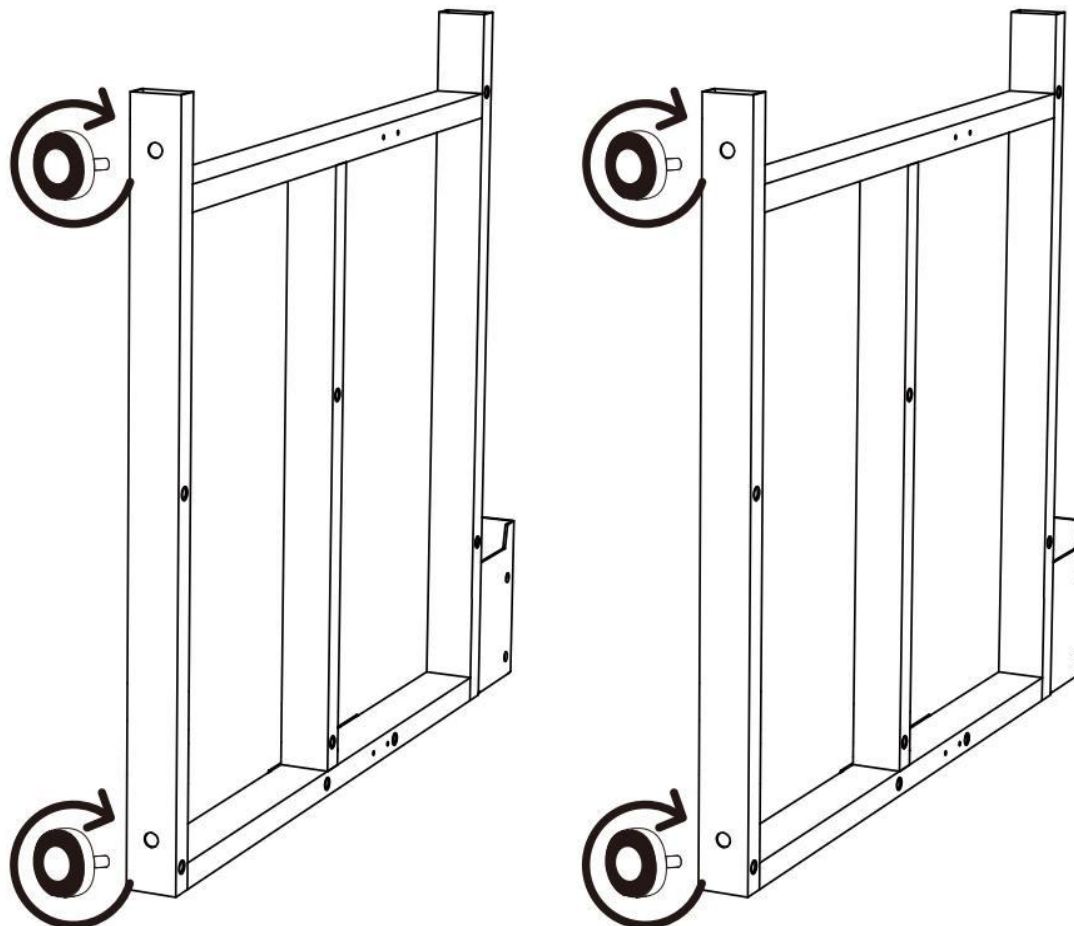

步驟2：將背面零件(A)平放在地板上。

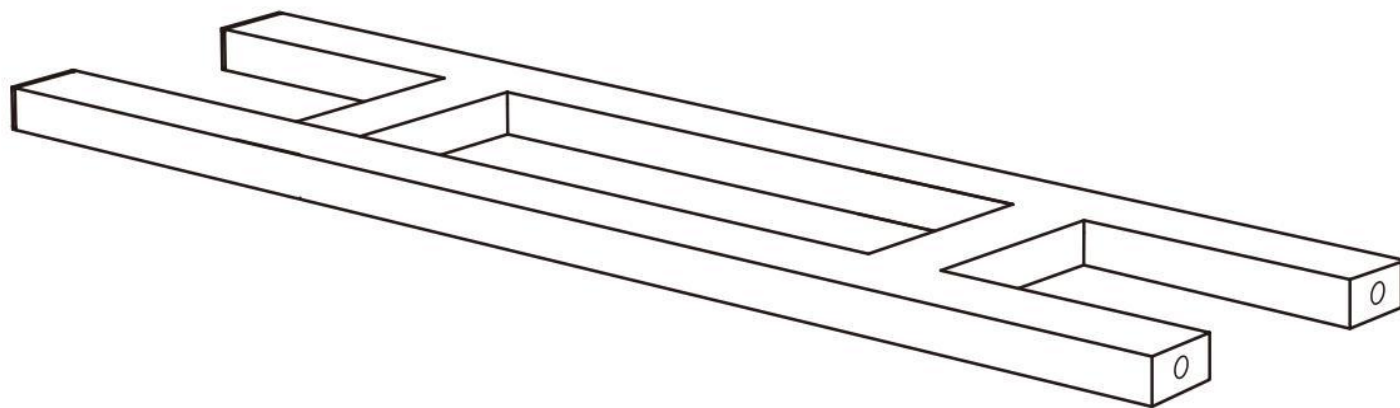

A 組件背面

步驟3：連接背部(A)以及側邊零件(B)，將6x50 mm螺絲(F)鎖緊至80%，不要完全鎖緊。



順時針擰緊

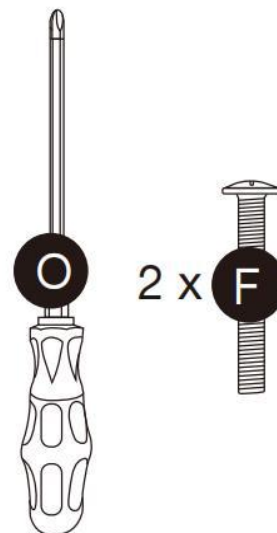
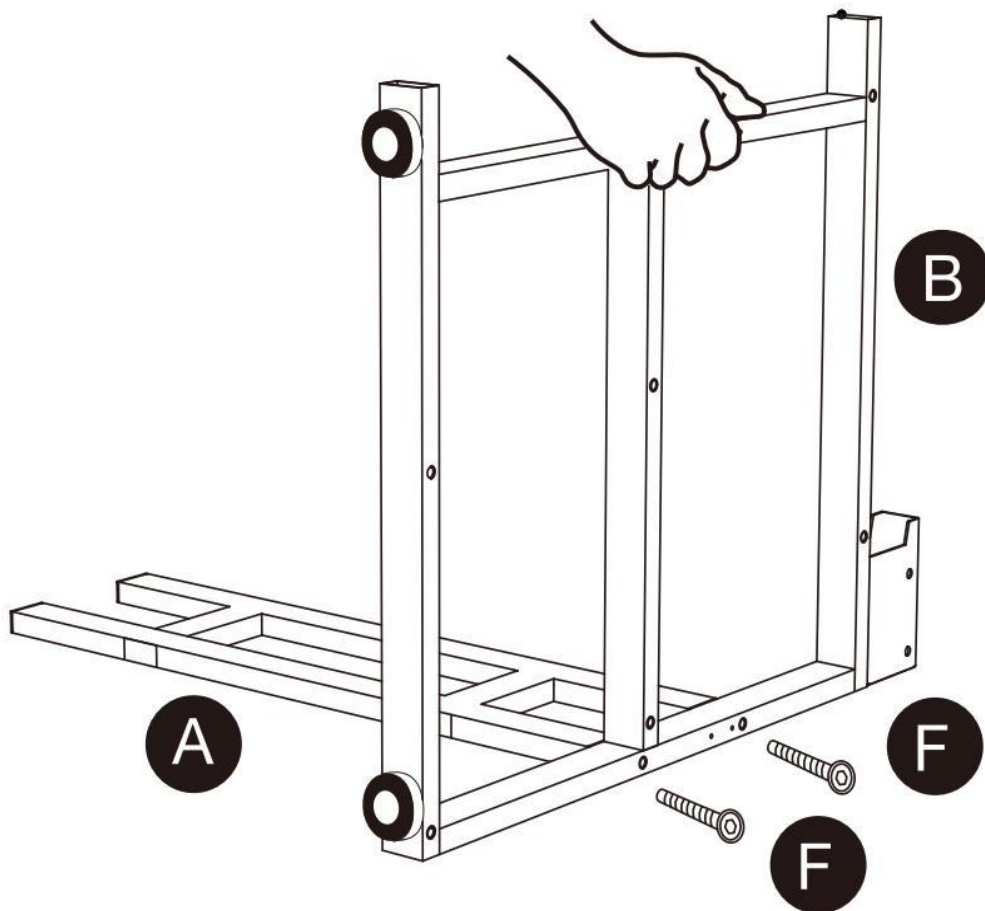

步驟4：重複步驟3安裝另外一個側面部件(B)，

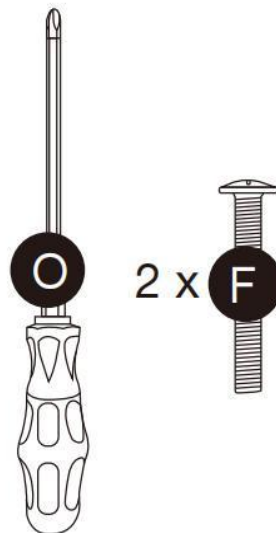
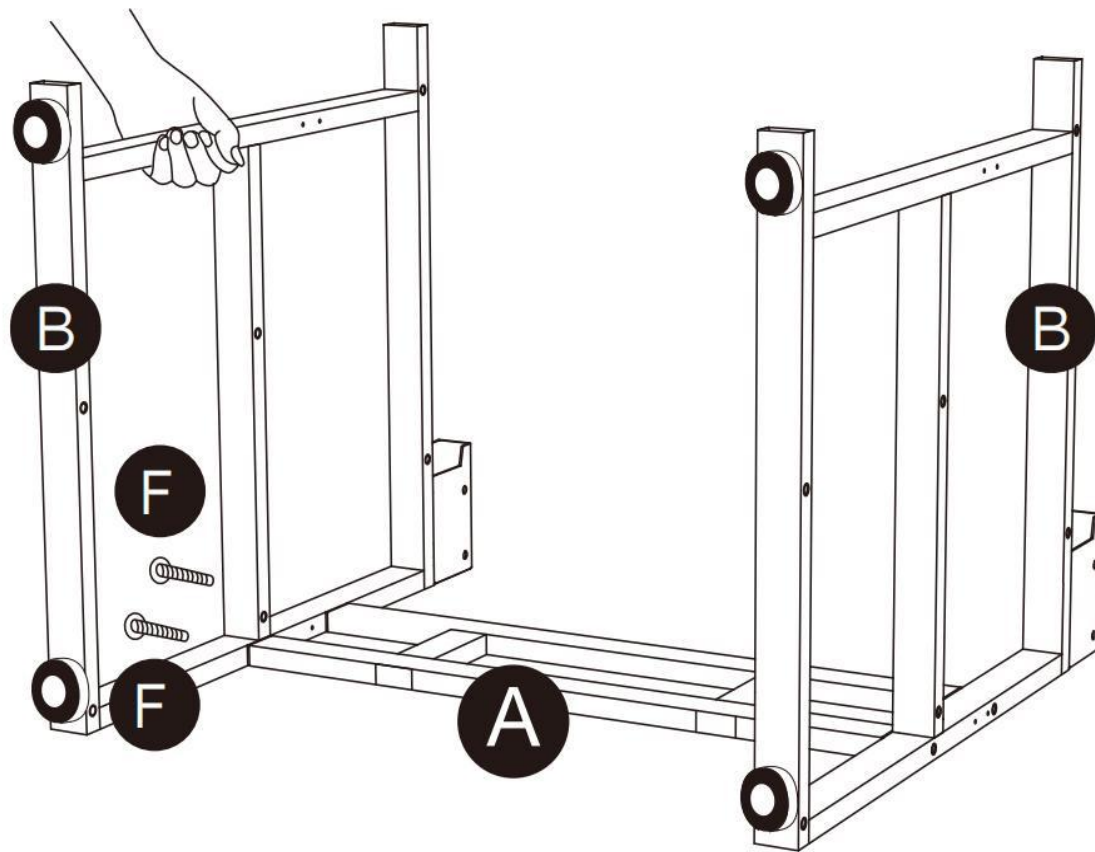

順時針擰緊



步驟5：安裝頂部(C)，將6x50毫米螺絲(F)鎖緊至80%，不要完全擰緊。

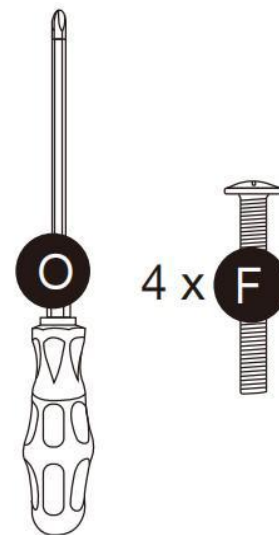
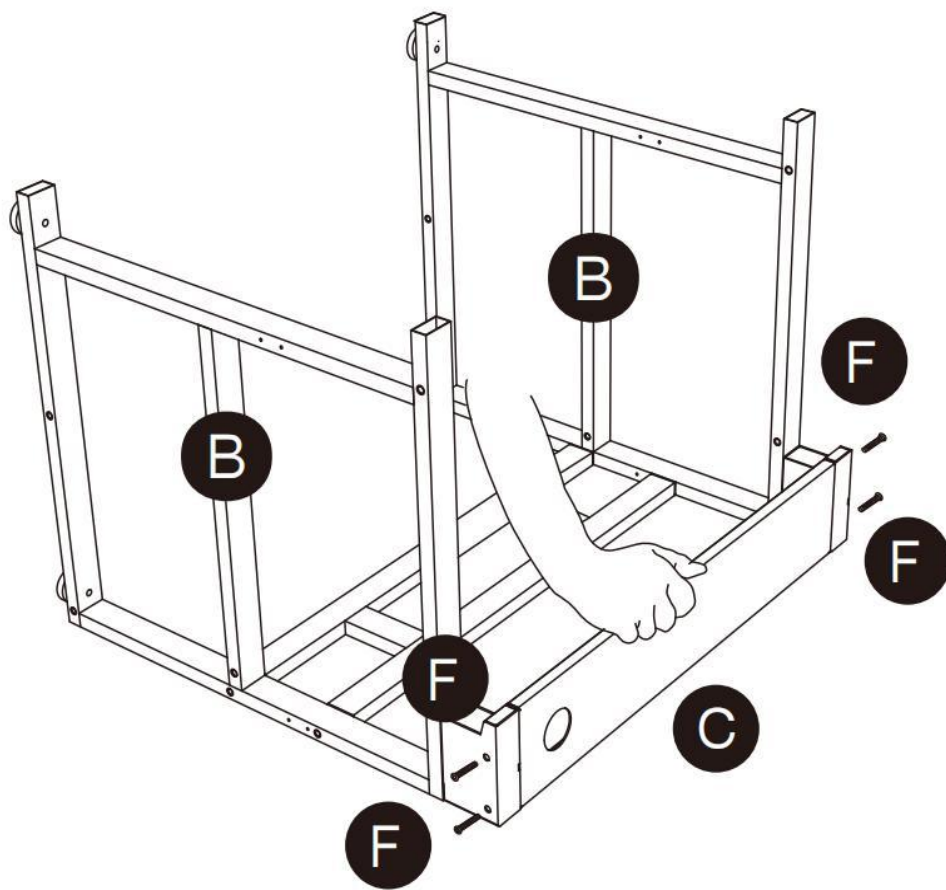

順時針擰緊



步驟6：安裝操縱台支架(D)，將6x50 mm螺絲(F)鎖緊至80%，請勿完全擰緊。



順時針擰緊

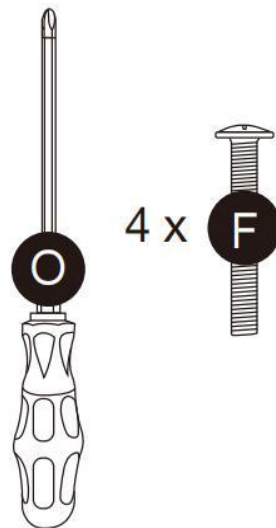
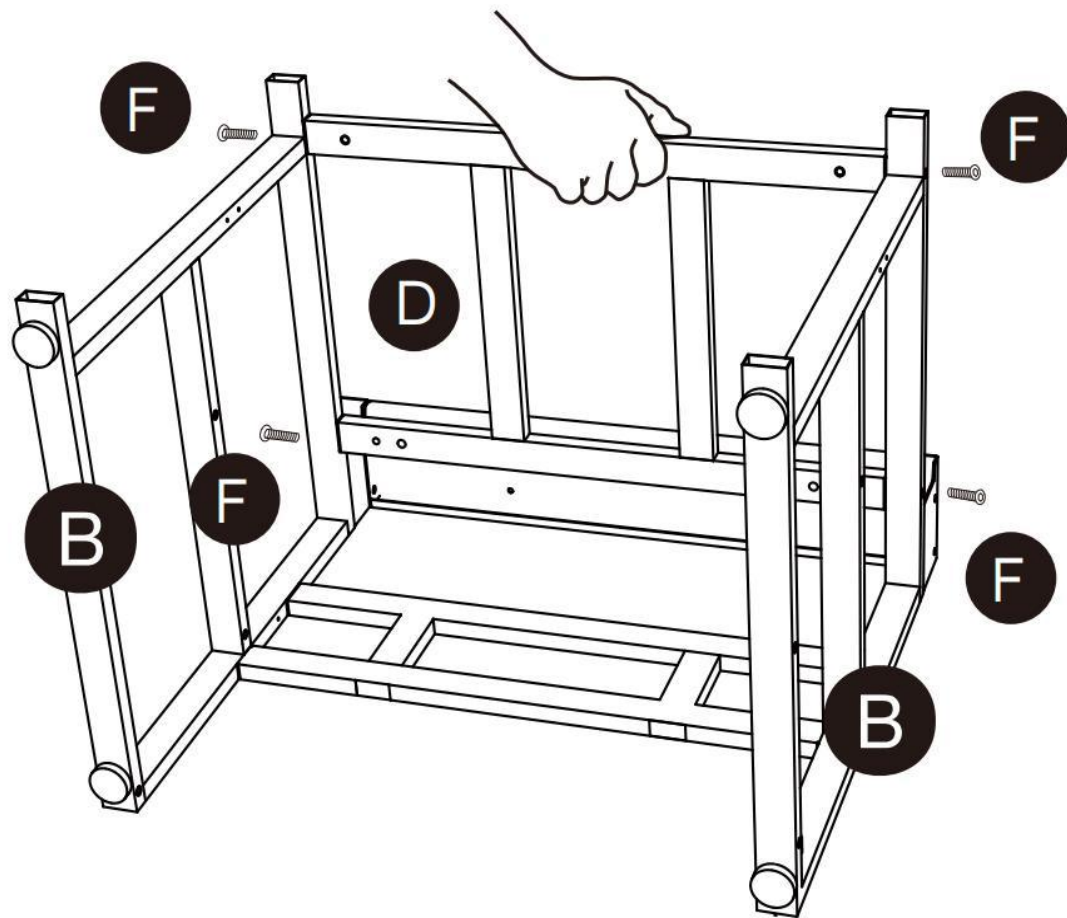

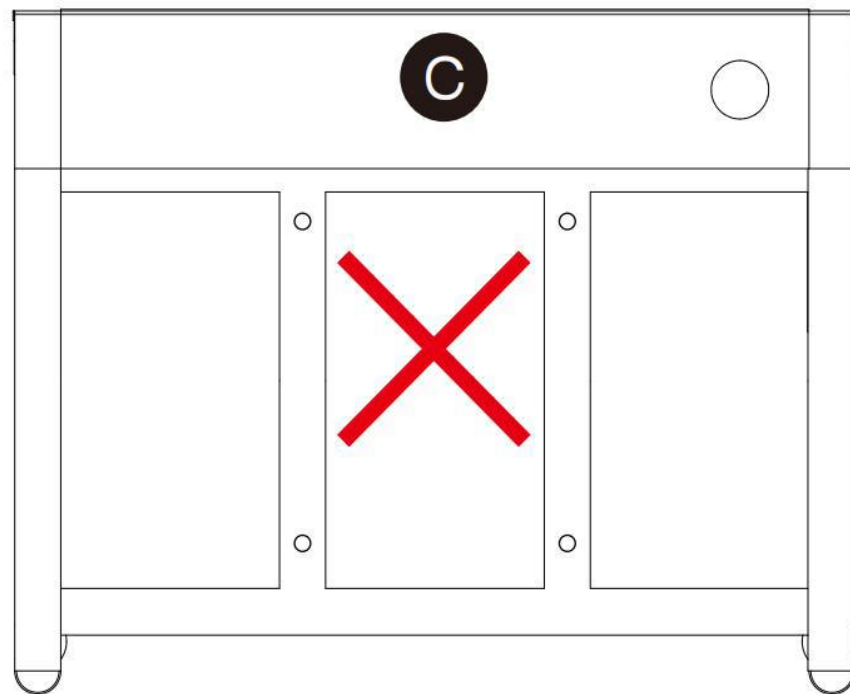
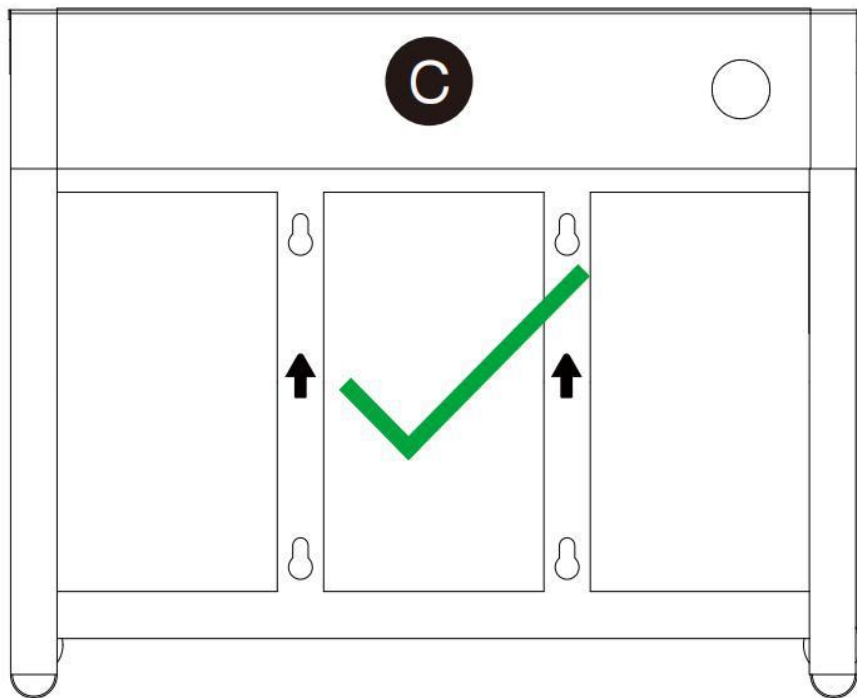

注意：貼紙箭頭指示指示，此面有防撞貼紙。請依照地圖，插孔朝上，大孔朝外。

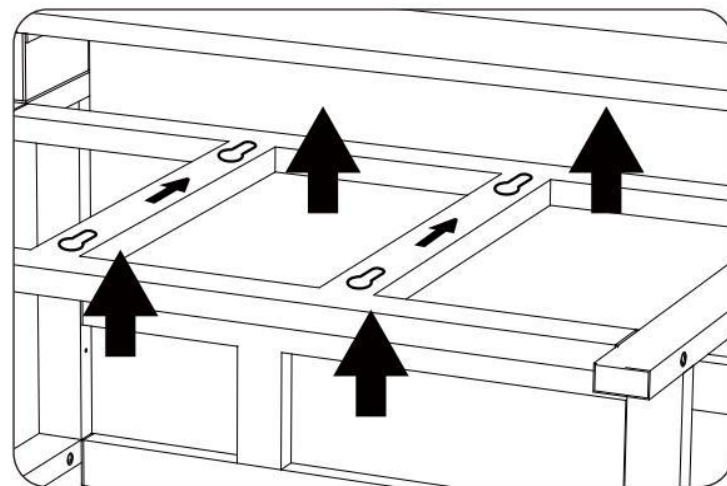

步驟7：安裝底部(E)，將6x50毫米螺絲(F)擰緊至80%，不要完全擰緊。

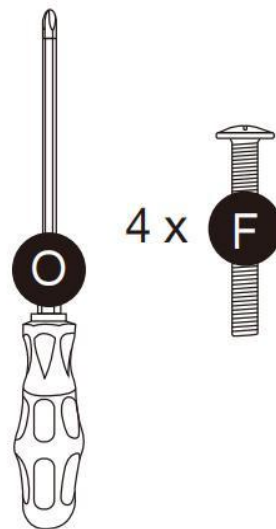
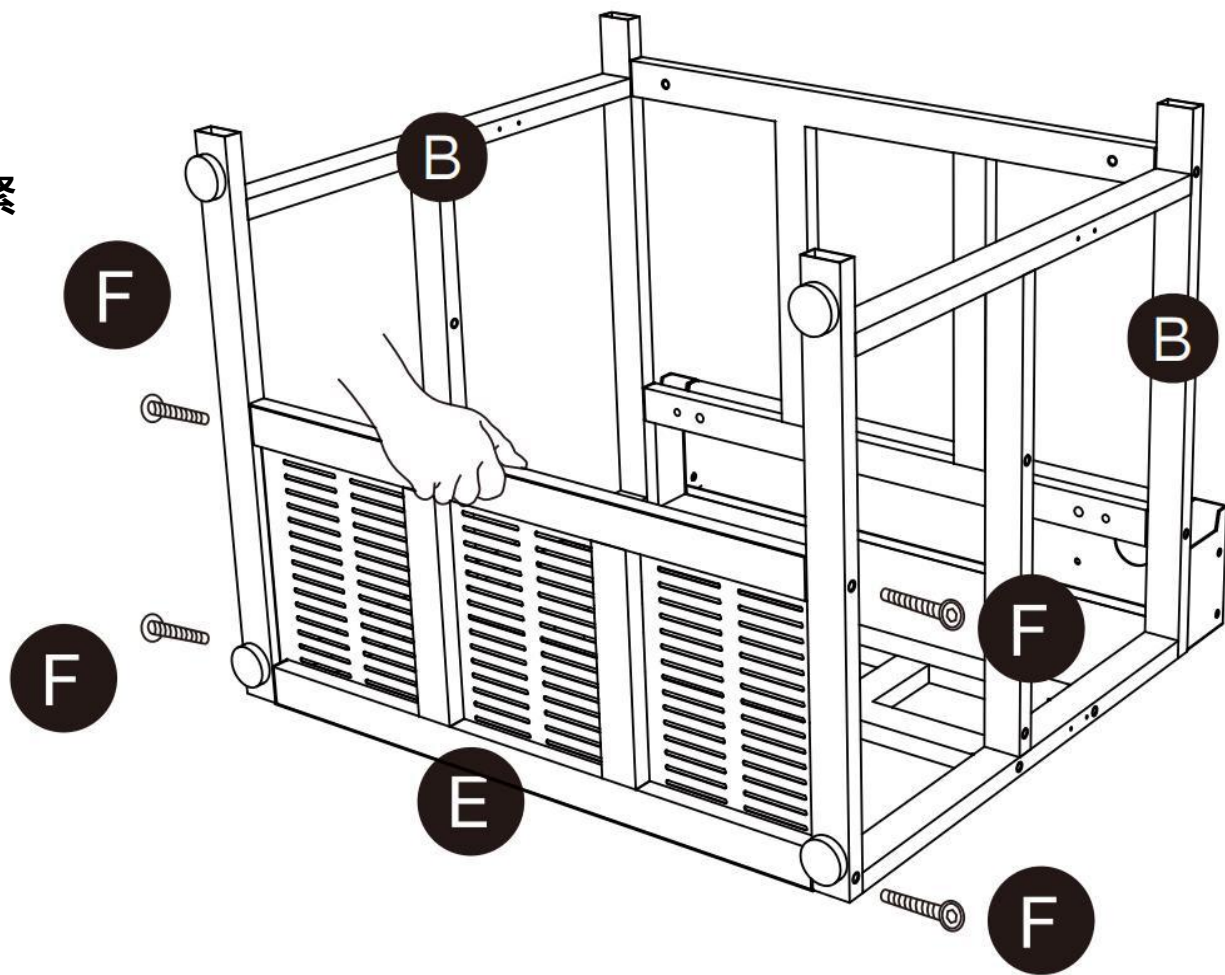

順時針擰緊

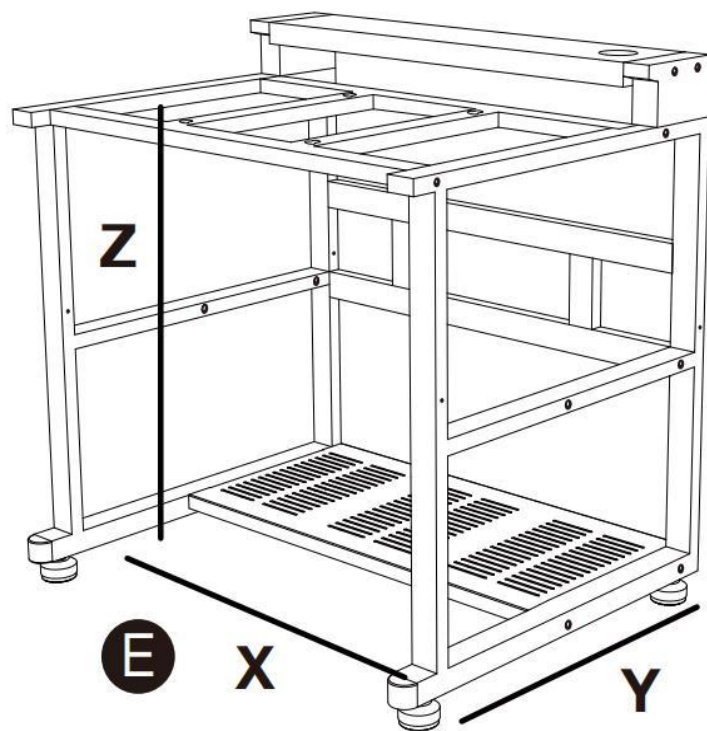

*底部(E)可以根據需要安裝在不同的位置

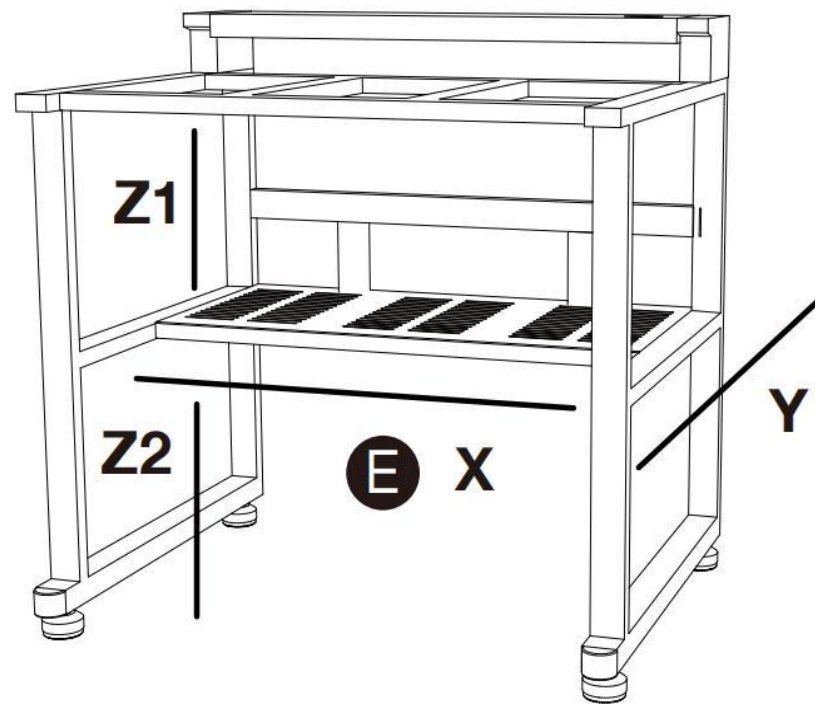

1



2

步驟8：把底座上6x50毫米螺絲(F)全部擰緊(16顆)。



順時針擰緊

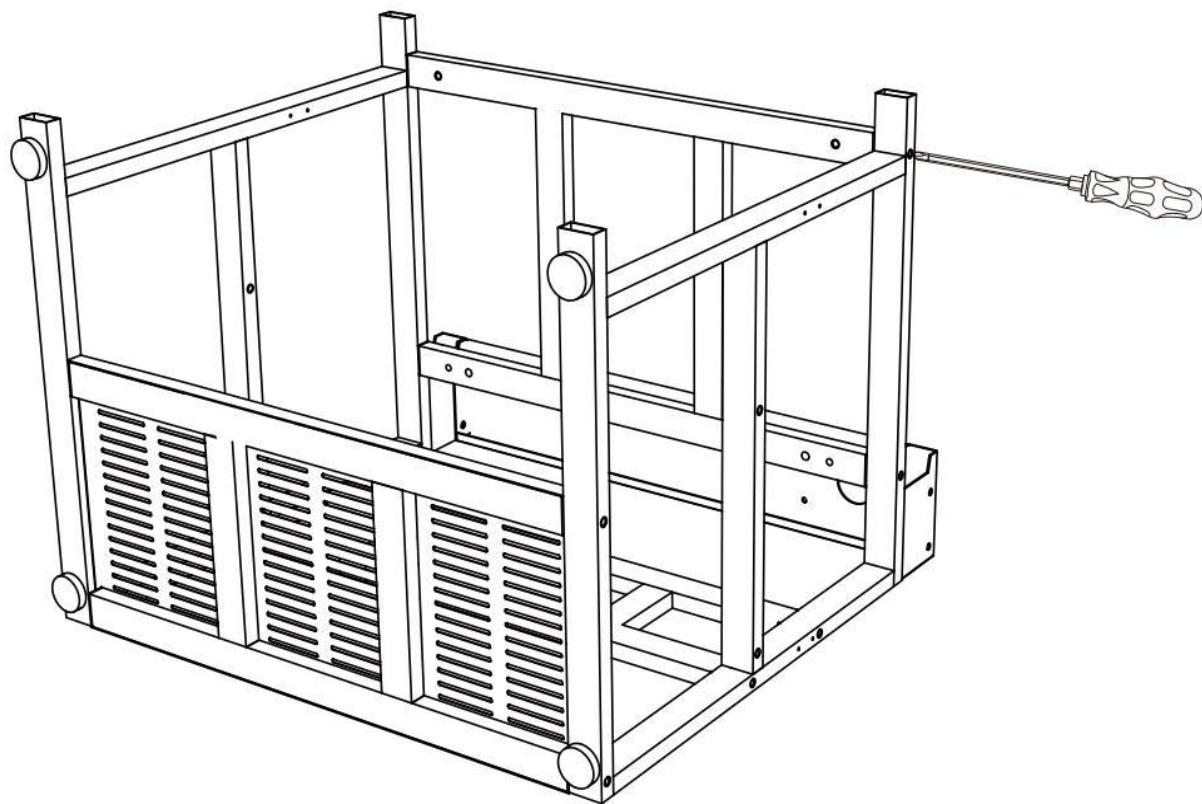

步驟9：翻轉整個支架

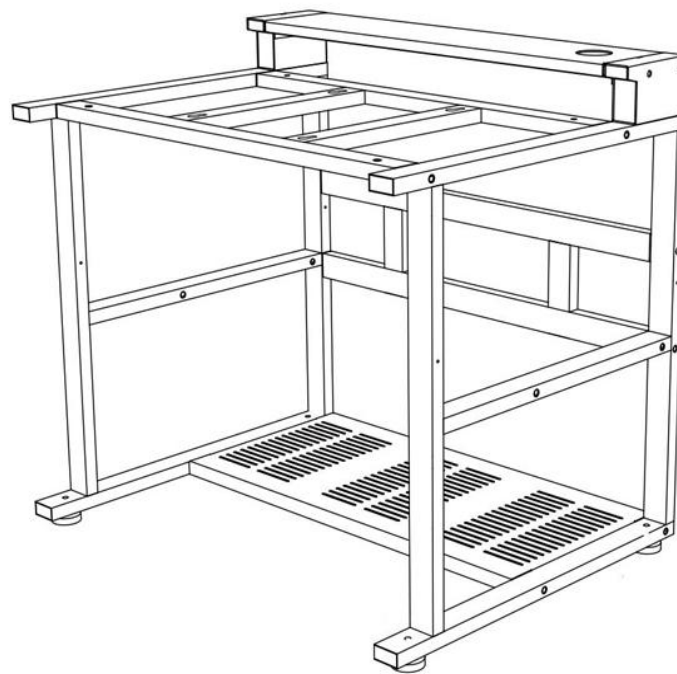
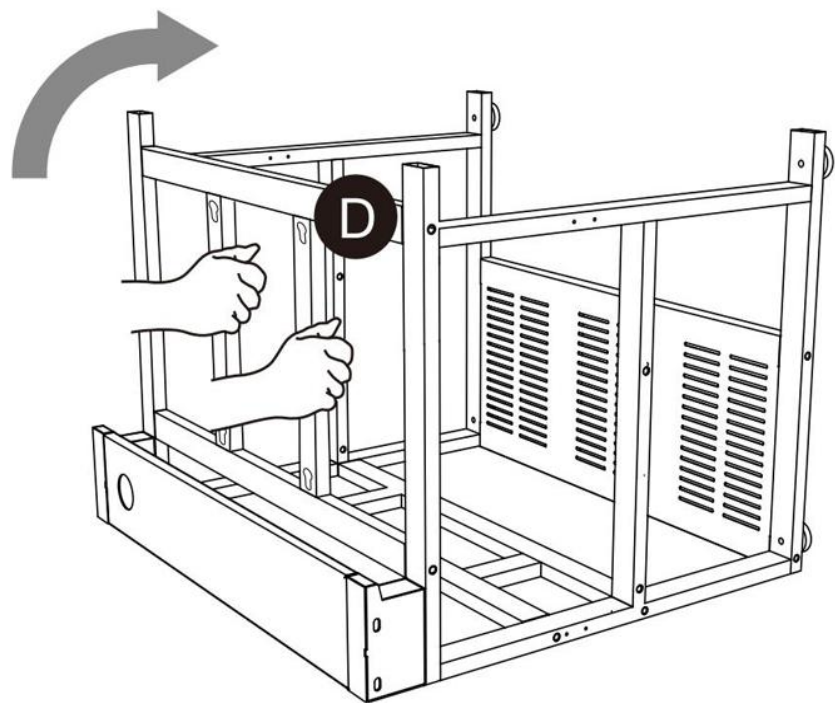

步驟10：調整腳杯(G)高度，讓支架水平平衡。

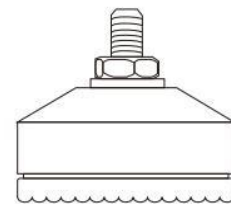

4 x **G**

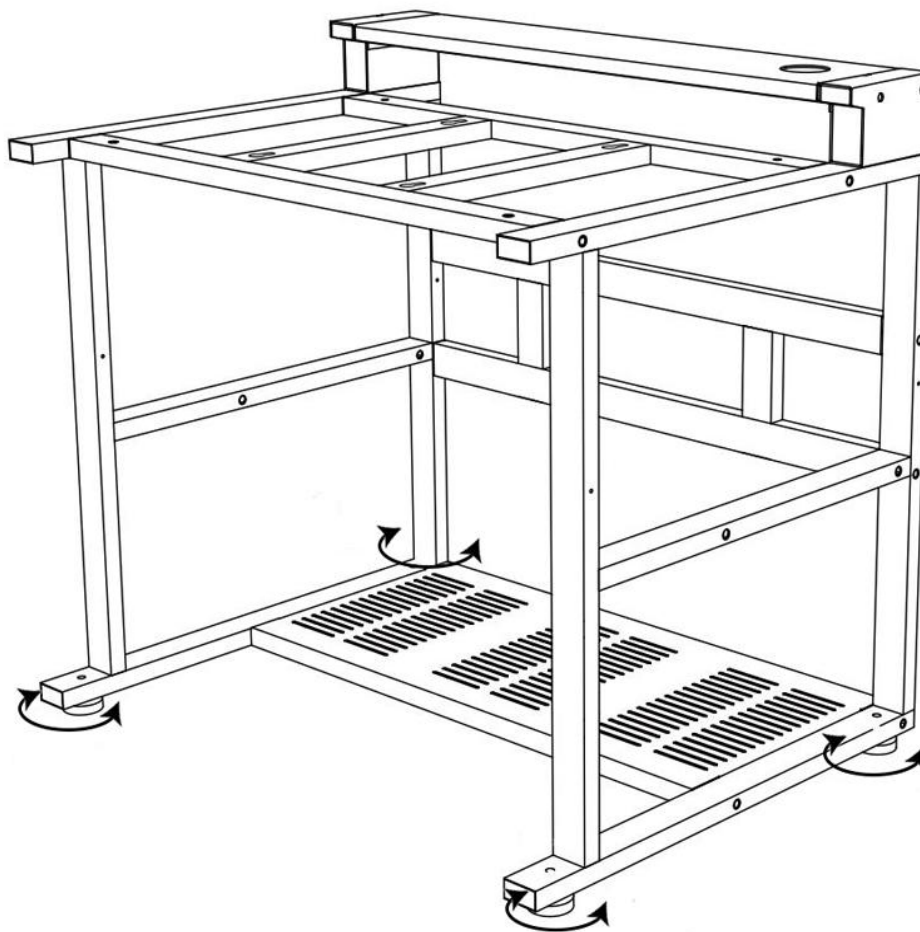

步驟11：將4個6x30mm螺絲(Q)擰緊至80%。請勿完全擰緊。



順時針擰緊

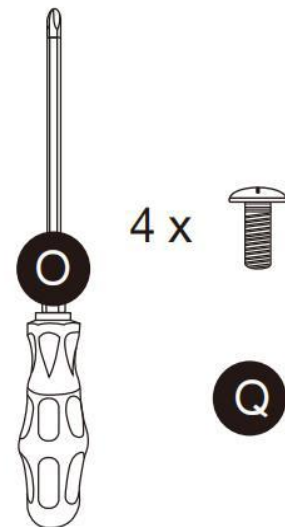
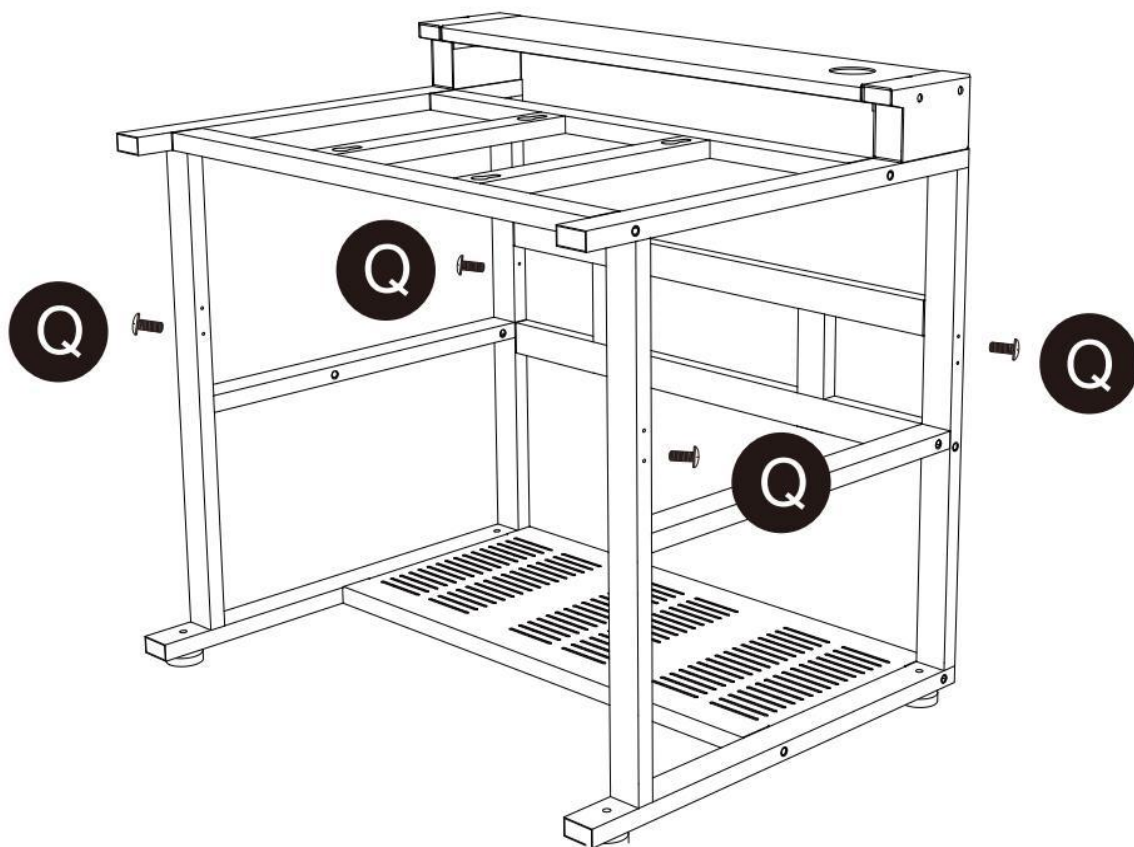

步驟12：把置物籃(J)掛在4個螺絲頭上，隨後完全擰緊4顆6x30mm螺絲(Q)



順時針擰緊

